

<b>A</b>	<b>TECHNICAL DATA.....</b>	<b>Page</b>	<b>4</b>
A1	HANDLING .....	Page	4
A2	UNPACKING.....	Page	4
A3	DISPOSAL.....	Page	4
A4	TECHNICAL DATA .....	Page	5
<b>B</b>	<b>INSTRUCTIONS FOR THE INSTALLER/MAINTENANCE PERSON.....</b>	<b>Page</b>	<b>7</b>
B1	WATER CONNECTION.....	Page	7
B2	ELECTRICAL CONNECTION .....	Page	7
B3	WARNING MESSAGES DISPLAYED ON THE CONTROL PANEL.....	Page	8
B4	DETERGENT/RINSE-AID DISPENSERS AND SETTINGS.....	Page	8
B5	SETTING THE DISPENSERS.....	Page	9
B6	MAINTENANCE.....	Page	10
<b>C</b>	<b>INSTRUCTIONS FOR THE USER.....</b>	<b>Page</b>	<b>11</b>
C1	STARTING.....	Page	11
C2	WASH CYCLES.....	Page	12
C3	OPERATION.....	Page	12
C4	END OF WORK AND DAILY CLEANING.....	Page	13
C5	REGENERATION CYCLE .....	Page	14
C6	WARNING MESSAGES DISPLAYED ON THE CONTROL PANEL.....	Page	15
C7	RESIDUAL RISKS.....	Page	15
<b>D</b>	<b>TROUBLESHOOTING .....</b>	<b>Page</b>	<b>16</b>

**WARNING**

**CAREFULLY READ THE INSTALLATION, OPERATING AND MAINTENANCE INSTRUCTIONS BEFORE INSTALLING THIS APPLIANCE. INCORRECT INSTALLATION, ADAPTATIONS OR ALTERATIONS COULD CAUSE DAMAGE TO PROPERTY OR INJURY TO PERSONS. MALICIOUS DAMAGE, DAMAGE DUE TO NEGLIGENCE, OR TO FAILURE TO COMPLY WITH INSTRUCTIONS AND REGULATIONS, OR TO INCORRECT CONNECTIONS OR UNAUTHORISED TAMPERING INVALIDATE ANY WARRANTY AND RELIEVE THE MANUFACTURER OF ALL LIABILITY.**

1. Carefully read this instructions booklet, as it contains important advice for safe installation, operation and maintenance.  
Keep this booklet to hand in a safe place for future reference by other operators.
2. **Installation should be carried out by qualified engineers, in accordance with current regulations and with the manufacturer's instructions.**
3. The appliance should only be used by persons specifically trained in this operation.
4. Switch off the appliance in the event of failure or malfunctioning.

Only have the appliance repaired by a service centre authorised by the manufacturer and ask for original spare parts.

**A1 HANDLING**

Use suitable means to move the appliance: a lift truck or fork pallet trucks (the forks should reach more than halfway beneath the appliance).

**A2 UNPACKING**

Wear protective gloves to unpack.

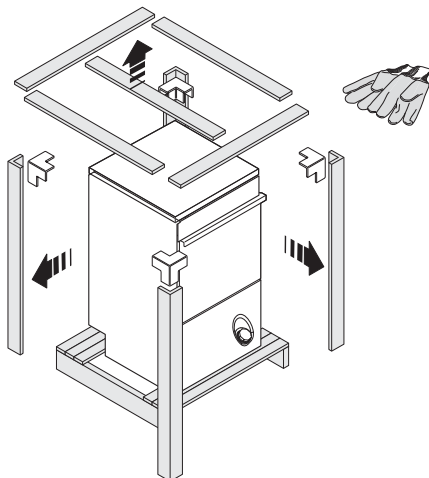

**Figure 1**

Lift the appliance using a lift truck, remove the base

and position the appliance where it is to be installed.

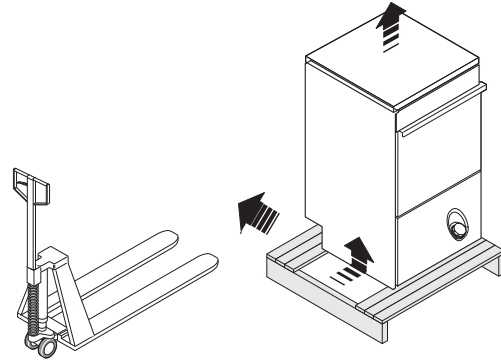

**Figure 2**

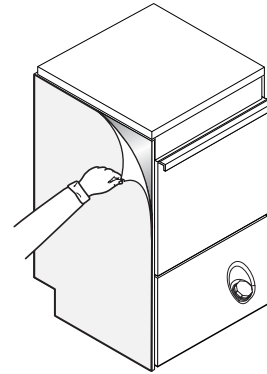

Remove the protective film and ensure that the packaging material is disposed of correctly in compliance with the regulations in force in the country where the product is to be used.



**Figure 3**

**A3 DISPOSAL**

All the packaging materials are environment friendly. They may be kept without danger, recycled or burned in a special waste incineration plant. Recyclable plastic components are marked as follows:

	<b>polyethylene</b>	<b>external wrapping film, instruction bag.</b>
	<b>polypropylene</b>	<b>top packaging panels, straps.</b>
	<b>polystyrene</b>	<b>protective surround elements.</b>

Wood and cardboard components may be disposed of according to local regulations in force. Appliances that have reached the end of their service life should be suitably disposed of. The appliance should be dismantled according to regulations in force. All metal parts are in stainless steel (AISI 304) and are removable. Plastic parts are marked with the symbol of the material.

## A4 TECHNICAL DATA

MODEL		NUC1-EUC1 WS	NUC3-EUC3 WS
Supply voltage:	V	220...240- 1N~	400...415- 3N~
- convertible to	V	-	220...240- 1N~
- convertible to	V	-	220...240- 3~
Frequency	Hz	50	50
Max. power input	kW	3,65/5,65(*)	5,35/7,35(*)
Boiler heating elements	kW	2,8	4,5
Tank heating elements	kW	2,0	2,0
Water supply press.	kPa [bar]	100...700 [1...7]	100...700 [1...7]
Water supply temp.	°C	50	50
Water supply hardness	°fH/°dH/°cH	40/22,4/28 max	40/22,4/28 max
Rinse cycle water consumption	l	3,3	3,3
Boiler capacity	l	5,8	5,8
Tank capacity	l	33	33
Standard cycle time with water supply at 50°C	sec.	120 - 180	120 - 180
Regeneration cycle time	min.	50	50
Legal noise level Leq	dB(A)	<70	<70
Protection rating		IPX4	IPX4
Net weight	kg	54	54
Power supply cable		H07RN-F	H07RN-F

(\*) = If activated by software, coincidence of tank and boiler heating elements.

Table 1

	400...415 V 3N		220...240 V 3		220...240 V 1N	
	C	S	C	S	C	S
3,65 kW	-	-	-	-	3X2,5	20 A 1P+N
5,35 kW	5X1,5	16 A 3P+N	4X2,5	20 A 3P+N	3X4	32 A 1P+N
5,65 kW	-	-	-	-	3X4	32 A 1P+N
7,35 kW	5X2,5	25 A 3P+N	4X4	32 A 3P+N	3X6	40 A 1P+N

C = Power supply cable  
S = On/Off switch

Table 2

Standard cycle time may vary should the inlet water temperature be different from that indicated above.

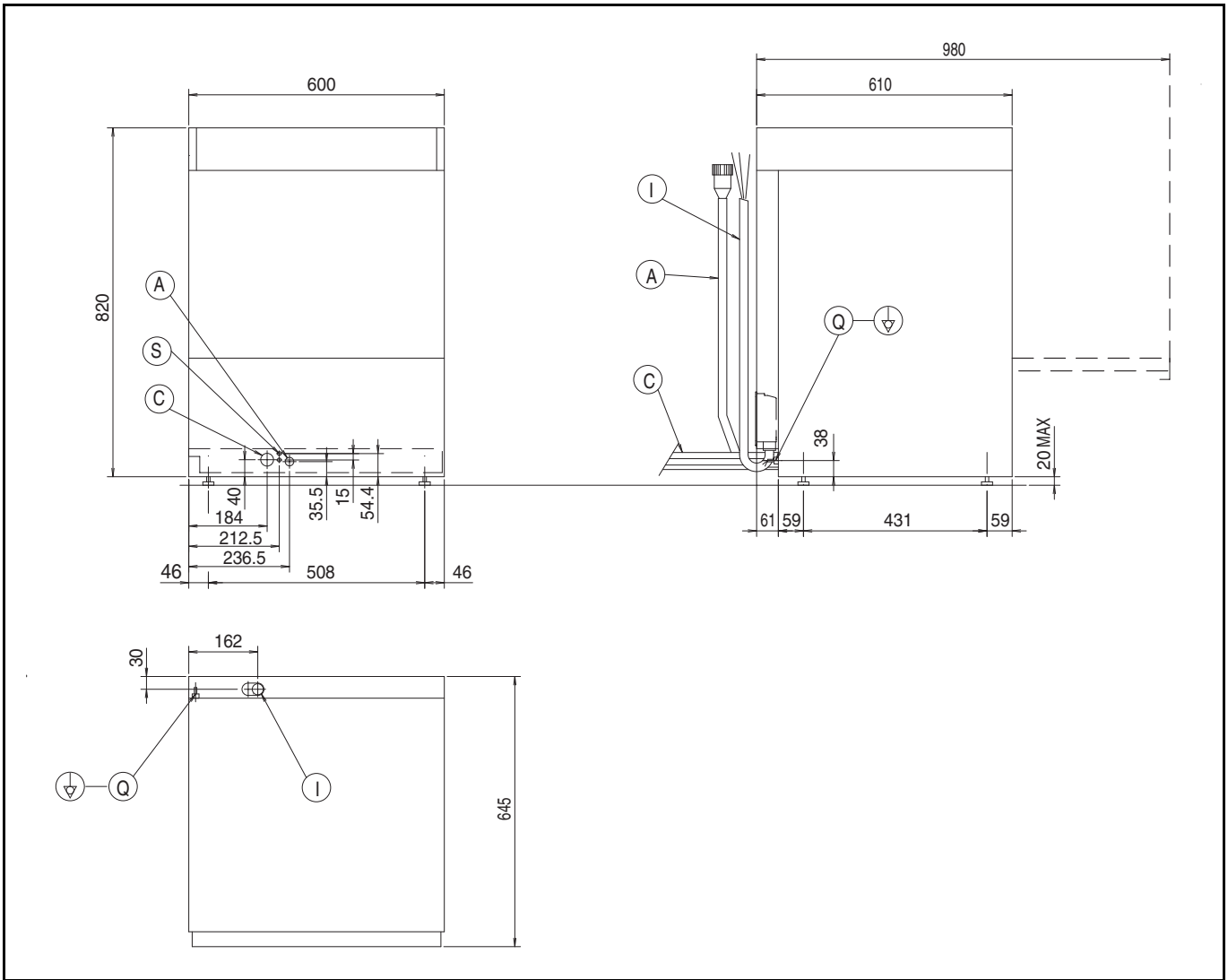

**Figure 4**

**Legend figure 4**

- A** - Water inlet pipe with  $\varnothing$  3/4" G fittings
- C** - Outlet pipe  $\varnothing$ i 40 mm (^) –  $\varnothing$ i 18mm (\*)
- I** - Power supply
- S** - Pipe inlet for detergents
- Q** - Unipotential screw
- (^) - Only for model with free-fall drainage
- (\*) - Only for model with drain pump

# B INSTRUCTIONS FOR THE INSTALLER/MAINTENANCE PERSON

Install a disconnecting switch with a capacity at least equal to that given in the technical data table, a 30 mA residual current circuit breaker and an overcurrent device (magnetothermal cut-out with manual reset or fuse) between the appliance and the mains power outlet.

The chosen device must be lockable in the open position in case of maintenance.

## RATING PLATE

The rating plate contains identification and technical data and is located on the right-hand side panel of the appliance (Figure 5).

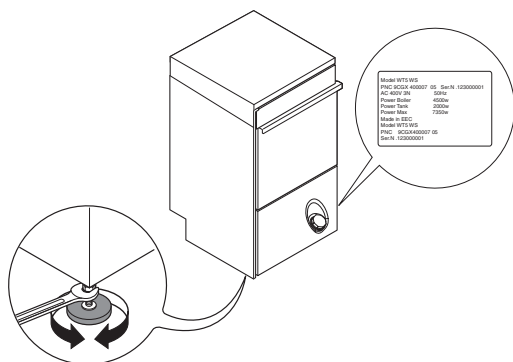

Figure 5

## B1 WATER CONNECTION

- Position the dishwasher and level the appliance by turning the relative height-adjustable feet (Figure 5).
- Connect the appliance water supply pipe "A" (Figure 4) to the mains, fitting a cut-off cock, the filter provided and a pressure gauge between the appliance and the mains (Figure 6).
- In NUC1G/ EUC1G models with incorporated water softener, connect the double non-return valve "B" (Figure 6) supplied and the machine supply pipe.

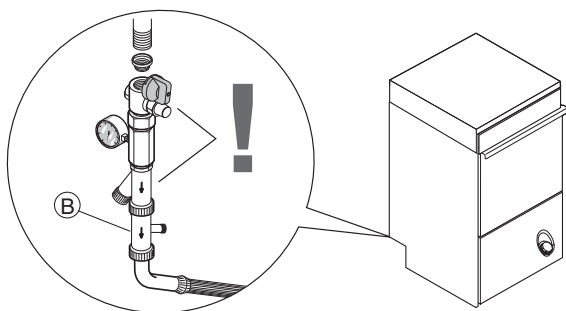

Figure 6

- Check that the **dynamic** water supply **pressure**, measured between the appliance and the main, is **between 100 and 700 kPa** (test while dishwasher tank or boiler is filling with water).  
**If the pressure is too high, fit a suitable pressure reducer on the inlet pipe.**

### - On the model with free-fall drainage:

connect the waste outlet pipe "C" (Figure 4) to the main drain pipe, fitting a trap, or place the outlet pipe over an S trap set into the floor.

### - On the model with drain pump:

position the outlet pipe at a height anywhere between 750 and 1000 mm from the floor.

Check that about 4 litres of water flow out of the outlet pipe during the rinse cycle.

## B2 ELECTRICAL CONNECTION

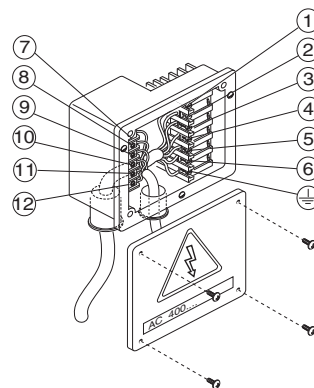

Figure 7



### CAUTION:

**THE EARTH AND ELECTRICAL CONNECTIONS SHOULD BE IN COMPLIANCE WITH NATIONAL REGULATIONS.**

- Before carrying out the electrical connection, check that the voltage and frequency on the appliance rating plate correspond to those of the mains electricity supply.
- The earth wire at the terminal end must be longer (max. 20 mm) than the phase wires.
- Connect the earth wire of the power supply cable to an efficient earth clamp. The appliance must also be included in a unipotential system, the connection being made through the screw "Q" (Figure 4) marked with the symbol "⚡". The unipotential wire must have a cross section of 10 mm<sup>2</sup>.

### Power supply 220...240 V 1N

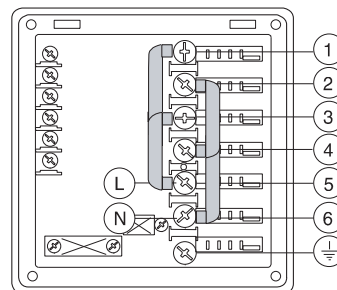
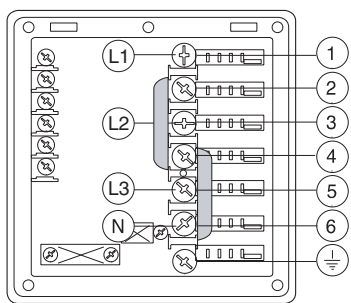

Figure 8

Open the power supply terminal board and insert the jumpers provided as follows: two jumpers between terminals 1, 3, 5 and another two between terminals 2, 4 and 6.

Using a suitable power supply cable (see technical data table), connect the phase and neutral to terminals 5 and 6 respectively and the earth wire to the terminal ⚡.

**Three-phase version:  
Power supply 400...415V 3N**



**Figure 9**

Open the power supply terminal board and insert the jumpers provided as follows: one jumper between terminals 2 and 4 and one between terminals n. 4 and 6. Using a suitable power supply cable (see technical data table), connect the three phases to terminals 1, 3 e 5, connect the neutral to terminal 4 and the earth wire to the terminal  $\perp$ .

**Power supply 220...240V 3**

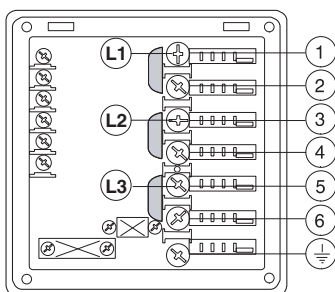
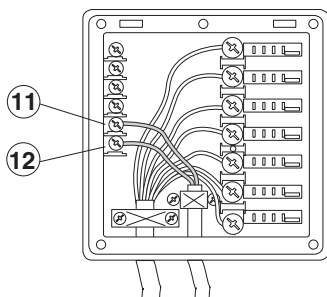

**Figure 10**

Open the power supply terminal board and insert the jumpers provided as follows: one jumper between terminals 1 and 2, one between terminals 3 and 4 and another between terminals 5 and 6. Using a suitable power supply cable (see technical data table), connect the three phases to terminals 1, 3 and 5 and the earth wire to the terminal  $\perp$ .

**Connections provided for energy control.**

This appliance is designed for an external energy consumption control.



**Figure 11**

Connect the energy peak controller across terminals 11 and 12.



**CAUTION:**

A normally open (n.o.) contact of the controller must be connected across terminals 11 and 12. When this contact closes the boiler heating elements are disconnected. Using the dishwasher in these conditions may increase the cycle time.

**Safety devices**

- An automatic reset thermoamperometric protective device incorporated in the windings of the electric pump cuts off the electricity supply in the case of malfunctioning.
- In the event of water mains failure, a device prevents water in the boiler from returning into the mains.
- An overflow pipe, connected to the drainage outlet, maintains the water in the tank at a constant level.
- On models with a drain pump, a supplementary level control device activates if the main level control device is faulty.

**Failure to comply with safety rules and regulations relieves the manufacturer of all liability.**

**B3 WARNING MESSAGES DISPLAYED ON THE CONTROL PANEL**

**A1 NO WATER**

- Check that the cock is open.
- Check that the water inlet filter is clean.
- Check the minimum mains pressure (not less than 50 kPa).
- Check that the overflow pipe is inserted (for appliances without drain pump only).

**B1 INEFFICIENT DRAINAGE**

- Check if the overflow has been removed.
- Check for obstruction on the waste outlet pipe and the overflow aperture.

**B2 TANK WATER LEVEL TOO HIGH**

- Check for obstruction on the waste outlet pipe and the overflow aperture.

**C1..C8 CALL THE SERVICE CENTRE**

**E1..E8 CALL THE SERVICE CENTRE**

- The appliance continues to operate, but appropriate checks by a technician are recommended.

**B4 DETERGENT/RINSE-AID DISPENSERS AND SETTINGS**

If the appliance is connected to a water softener or osmotic device, contact the detergent supplier for a specific product.

Peristaltic dispensers (rinse-aid and detergent) require periodic maintenance. The internal hose of the rinse-aid dispenser should undergo periodic maintenance (at least once or twice a year).

**1. Dishwasher with incorporated detergent dispenser pump (Figure 12)**

Pump “R” dispenses about 0.9 g/s of detergent. When the appliance is filled with water for the first time in the day, it dispenses about 67 g of detergent in 70 sec., thereby providing a concentration of 2 g/l. Pump “R” dispenses about 8 g in 8 sec. at each cycle.

Dispenser operating time may be changed, following the instructions given in the next paragraph. Insert the hose provided in the kit into the detergent container.

**2. Dishwashers with incorporated peristaltic rinse-aid dispenser pump (Figure 12).**

Pump “S” dispenses about 0.1 g/s of rinse-aid. It dispenses about 0.4 g in 4 sec. at each rinse. Dispenser operating time may be changed, following the instructions given in the next paragraph. Insert the hose provided in the kit into the rinse-aid container.

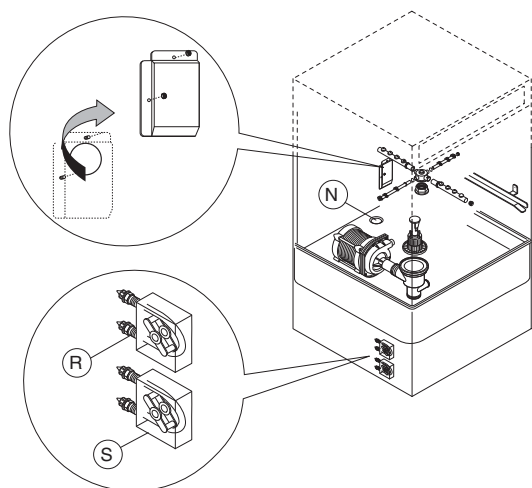

Figure 12

There is a ready-made impression “N” to be perforated (Ø 8 mm) for positioning the detergent concentration measuring sensor.

**Electrical connections for automatic detergent and rinse-aid dispensers.**

Terminals are available on the power supply terminal board for the electrical connection of external dispensers working at 220...240 V. Max. power 30 VA.

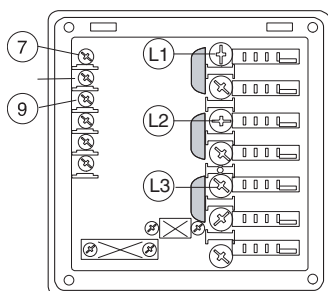

Figure 13

- Connect the **detergent dispenser** between terminals 7 and 9. These connection points are live for a set time during filling of the tank and at the start of

the wash cycle (see paragraph “Setting the dispensers”).

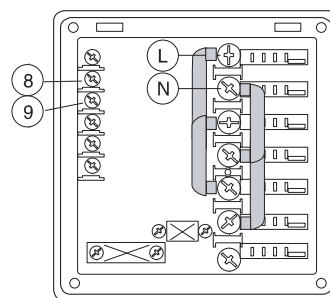

Figure 14

- Connect the **rinse-aid dispenser** between terminals 8 and 9. These connection points are live during filling of the tank and at the end of the rinse cycle for a set time (see “setting the dispensers” paragraph).

**MANUAL ACTIVATION**

Whenever the detergent containers are replaced, it may be necessary to activate the dispensers manually in order to fill the hoses and eliminate any air.

Simultaneously press the buttons, as shown in the figures below. If necessary, repeat this operation several times.

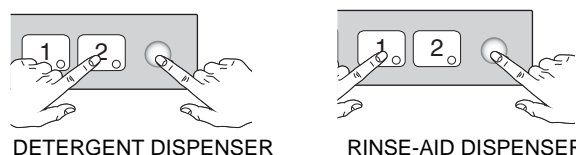

**B5 SETTING THE DISPENSERS**

**Peristaltic dispensers**

All operations should be carried out with the appliance switched on, the door open and no cycle selected.

**LEGEND**

- ▲ increase
- ▼ decrease
- ☞ confirm or select next parameter

**SEQUENTIAL START**

Press the indicated buttons simultaneously for 5 seconds:

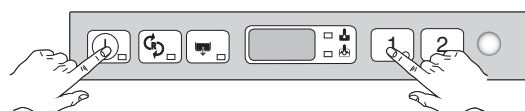

Display of programming mode:

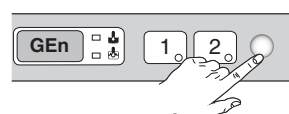

Initial amount of detergent:



Setting the activation time:

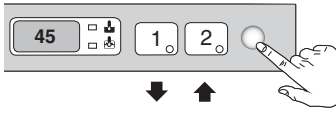

Initial amount of rinse-aid:



Setting the activation time:

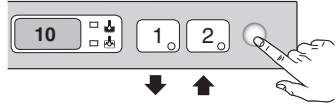

Amount of detergent during the cycle:



Setting the activation time:

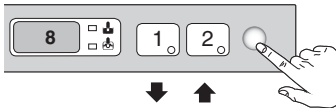

Amount of rinse-aid during the cycle:



Setting the activation time:

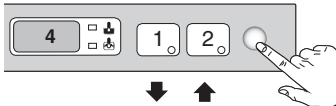

Exit from programming mode:

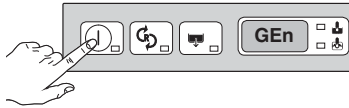

#### Notes for external dispensers:

- if  $dEt = 101$  the **detergent dispenser** only operates during **wash pump** operation; terminals **7-9** of the main terminal board are powered at the same time.
- if  $dEt = 102$  the **detergent dispenser** only operates during **filling electrovalve** operation for restoring the boiler level; terminals **7-9** of the main terminal board are powered at the same time.
- if  $rA = 61$  the **rinse-aid dispenser** only operates during **filling electrovalve** operation for restoring the boiler level; terminals **8-9** of the main terminal board are powered at the same time.
- if  $rA = 62$  the **rinse-aid dispenser** only operates during **wash pump** operation; terminals **8-9** of the main terminal board are powered at the same time.

For connections, see the wiring diagram.

#### Example:

Supposing that an external detergent dispenser has been connected with a tank concentration measuring sensor, a standard setting could be as follows:

$dIn = 0$  the dispenser is not activated during filling of the tank.

$dEt = 101$  the dispenser is activated during wash pump operation and, thanks to the concentration measured by the conduction sensor, the correct amount of detergent is dispensed.

**Suggestion:** to check the effectiveness of the rinse-aid, look at freshly washed glasses against the light. Drops of water remaining on the glass indicate an insufficient amount while streaks indicate an excess.

#### Changing the detergent/rinse-aid type

If changing to a different detergent/rinse-aid type (even one by the same manufacturer), you must rinse the suction and pressure hoses with fresh water before connecting the new detergent/rinse-aid container. Otherwise, the mixing of different types of detergent/rinse-aid will cause crystallisation, which may result in a breakdown of the dosing pump. Failure to observe this condition will invalidate the guarantee and product liability.

## B6 MAINTENANCE

- Descale the boiler, the internal surfaces of the tank and the appliance water piping once or twice a year.
- Descale the rinse and wash jets every month using vinegar or a descaling agent.
- The internal hose of the rinse-aid and detergent peristaltic dispenser should undergo periodic maintenance (once or twice a year).

#### Prolonged period of inactivity.

If the dishwasher is not to be used for a long time, proceed as follows:

- Close the water supply cock.
- Completely drain the tank.
- Remove and carefully clean the filters.
- Completely drain the incorporated dispenser hoses, removing them from the containers. Repeat the procedure described in the paragraph "Manual activation" at least 3 times.
- Completely drain the boiler by simultaneously pressing the buttons as shown in the figure:

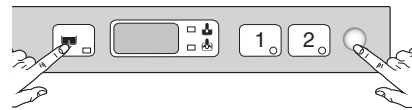

A buzzer indicates completion of drainage.

- Spread a thin film of Vaseline oil over all the stainless steel surfaces.

#### Preventive maintenance

The preventive maintenance call may be activated (see service manuals). Upon reaching the set number of cycles (e.g. 20000),  $CAI :$  appears on the display. This message advises calling a qualified technician for a general check-up of the state of the appliance.

Our appliances have been studied and optimised to give high performance. This appliance must be used exclusively for the purpose for which it has been designed, i.e. for washing dishes with water and specific detergents. Any other use is to be considered improper.

This appliance does not carry out the rinse cycle should there be no supply water; it stops all functions with an error message "A1" (also see "Warning messages").

### WARNING

- Carry out a couple of cycles without dishes to flush out any industrial grease which has remained in the tank and piping.
- Avoid washing decorated dishes.
- Do not allow silverware to come into contact with other metals.
- Do not allow food to dry on the dishes.
- Remove large food scraps from the dishes to prevent clogging the filters.
- Pre-wash the dishes by spraying them with cold or lukewarm water, without using any detergent.
- Use automatic dispensers for the detergent.
- If there is no automatic dispenser, pour a non-foaming detergent into the tank when the water has reached the washing temperature.

### CONTROL PANEL

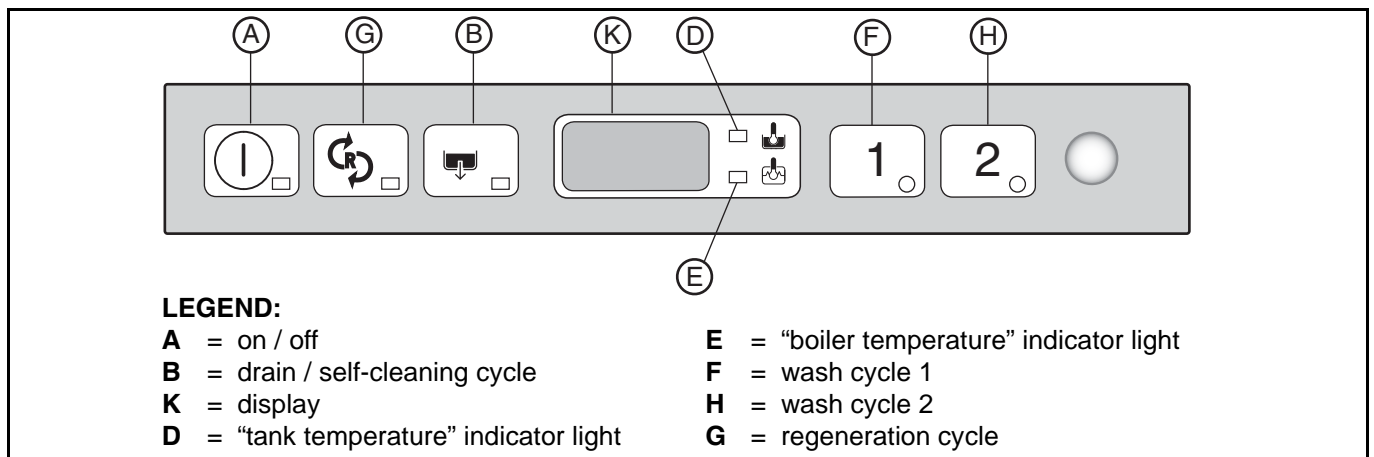

Figure 15

The temperature shown on the display is that of the boiler if the indicator light "E" is on or of the tank if the light "D" is on. The tank temperature is displayed during the wash cycle and the boiler temperature during the rinse cycle.

### C1 STARTING

- Open the water supply cock.
- Switch on at the mains.
- Open the door and check that all the components are in their correct position.
- Close the door and press button "A".



The indicator light of button "A" (Figure 15) comes on, indicating that the dishwasher is powered and that water is being introduced and heated. The word "FILL" is shown on the display during the entire filling and heating stage:



Warning, this dishwasher does the first tank filling through several consecutive hot rinse cycles, while the display shows the message FILL (flowing).

This system let save up to 30% of time than traditional models.

If the door is opened during this stage the message "CLOSE" will appear on the display:



The filling and heating stage has finished when the display shows the tank temperature:

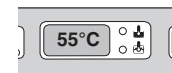

To display the boiler temperature during heating of the tank, open the door and press the button "F" (Figure 15).

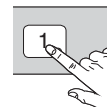

## C2 WASH CYCLES

The wash cycle includes one wash with hot water and detergent (min 55 °C) and one rinse with hot water and rinse-aid (min 82 °C).

### Table of times

Standard cycle time with supply water at 50 °C.

	1	2
NUC WS / EUC WS	120"	180"

A device lengthens the cycle time if the water in the boiler has not reached the minimum temperature for correct rinsing.

The cycle times and the temperature may be personalised (e.g. increase of the rinse time and temperature). The cycle times should only be set by a specialised technician.

## C3 OPERATION

The filling and heating stage has finished when the display shows the tank temperature:

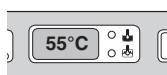

The appliance is then ready for use:

- Open the door.
- Pour the required amount of detergent into the tank.
- Insert the rack containing the dirty dishes.
- Close the door and select the suitable wash cycle; the corresponding indicator light comes on and the wash cycle starts.

Wash cycles:

### - Cycle I

For lightly soiled dishes or glasses: press button "F" (Figure 15), (see table of times).

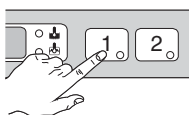

### - Cycle II (recommended)

For very dirty dishes: press button "H" (Figure 15), (see table of times).

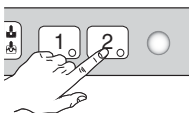

- To stop the wash cycle, just press the cycle button or open the door.
- To continue the wash cycle, press the cycle button again or close the door. The cycle starts from where it was interrupted.
- Upon completion of the wash cycle the dishwasher emits a series of beeps, the cycle indicator light blinks and the message "END" blinks on the display:



This dishwasher has a built-in counter which keeps track of how many wash cycles can be carried out before a regeneration cycle (see paragraph "regeneration cycle") must take place.

When the water softener device has an autonomy of just 15 cycles left, at the end of each wash cycle the display will alternately show the message "END" and the number of wash cycles (from 15 to 0) remaining before the message "REG" appears, indicating that regeneration is advised.

- Open the door and remove the rack containing the clean dishes.

### IMPORTANT

**The appliance will not remove burnt food deposits from dishes. Dishes with burnt-on food deposits should be cleaned mechanically/chemically (for example, pre-wash under running water) before putting them in the dishwasher.**

### IMPORTANT

**The use of "foaming"/non-specific detergents or in any case detergents used in different ways from that prescribed by the manufacturer, can cause damage to the dishwasher and compromise washing results.**

### IMPORTANT

**Failure to remove the residuals of detergent possibly used for manual prewash can cause malfunctioning of the dishwasher and compromise washing results.**

**Change the water in the tank at least once a day.**

### Type of racks and loading

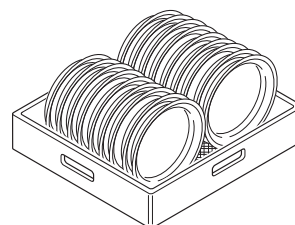

Figure 16

- YELLOW rack: for 18 plates with maximum diameter of 240 mm.

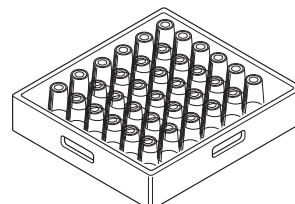

Figure 17

- BLUE rack for glasses: the glasses should be placed upside down.

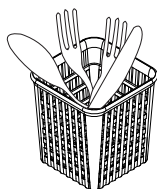

Figure 18

- YELLOW container for cutlery: insert items, with the handles pointing downwards, in each container.
- Available accessories: dividers for glasses, inserts to angle glasses, racks for glasses with different heights and diameters and rack for dishes with maximum diameter of 320 mm.

**C4 END OF WORK AND DAILY CLEANING**

The appliance is designed to carry out an automatic cleaning cycle to help flush out any residues and to guarantee greater health and hygiene:

- Open the door and take out the rack containing the clean dishes.
- Remove the tank filters and the overflow "W".

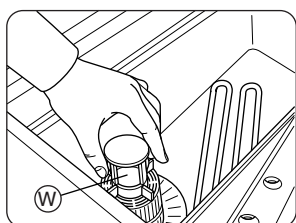
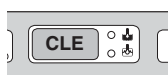

Figure 19

- Close the door.
- Select the drain cycle by pressing button "B" (Figure 15).



The message "CLE" ("CLEAN") will be displayed throughout the drain cycle:



- After a few minutes, 3 beeps indicate the end of the cleaning cycle and "END" blinks on the display:



- Switch off the dishwasher by pressing button "A" (Figure 15).



- Switch off at the mains.
- Close the water supply cock.
- Replace the overflow.

- Unscrew the ring nuts "H" and remove the header units "C".

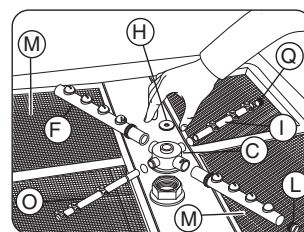

Figure 20

- Release the arms "F", "I" and "O" from the hub, remove the threaded plugs "L" and "Q" and clean all the parts with a water jet. Do not use tools or sharp implements to clean the nozzles, which could otherwise be damaged.
- Only if the filters "M" are present in the machine, remove and clean them with a jet of water.
- Remove the filter "Z" and clean away any remained food in order to avoid blocking the draining system.

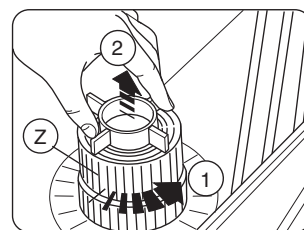

Figure 21

**IMPORTANT**

**CAUTION: THE RINSE ARMS "I" and "O" ARE NOT SYMMETRICAL; the rinse arm with raised ring (O) should be fitted onto hub socket.**

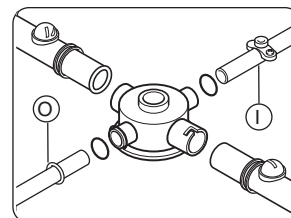

Figure 22

- Upon completion of cleaning operations, replace the parts removed previously.

**Cleaning the exterior surfaces**

Before carrying out any cleaning operations, turn off the power at the mains.

**IMPORTANT**

**Clean the stainless steel surfaces using warm soapy water; never use detergents containing abrasive substances nor steel scrapers, common wire wool, brushes or scrapers; rinse thoroughly using a wet cloth and carefully wipe dry.**

**Clean the control panel using a soft damp cloth and a neutral detergent if necessary.**

**Do not wash the appliance using direct or high-pressure water jets.**

To reduce the emission of pollutants into the environment, clean the appliance (externally and where necessary internally) with products having a biodegradability of over 90%).

## C5 REGENERATION CYCLE

To reduce problems caused by the presence of calcareous substances in the water supply, a water softener device has been fitted in the rinse circuit of the dishwasher. This device removes the calcareous substances from the feed-water, supplying decalcified water necessary for the washing.

For the correct operation of the water softener, the periodical regeneration of the resins, whose frequency depends on the number of washing cycles and water hardness, must be carried out.

The relevant water supply company will be able to provide all the instructions regarding the water hardness.

### Degrees of water hardness

Level	Characteristic	Degrees		
		°fH	°dH	°cH
1	soft	0 - 5.5	0 - 3	0 - 4
2	medium	7 - 14	4 - 8	5 - 10
3	hard	16 - 26.5	9 - 15	11 - 18.6
4	very hard	> 27	> 16	> 19

### WATER HARDNESS in °fH/°dH/°cH / REGENERATION FREQUENCY in Nr of cycles

°fH	°dH	°cH	Nr
10 - 15	5.6 - 8.4	7 - 10.5	200
16 - 20	9.0 - 11.2	11.2 - 14	140
21 - 25	11.8 - 14.0	14.7 - 17.5	100
26 - 30	14.6 - 16.8	18.3 - 21	70
31 - 35	17.4 - 19.6	21.8 - 24.6	50
36 - 40	20.2 - 22.4	25.3 - 28	30

The water softener device is factory-set to the value of 20 cycles since this is generally sufficient for most uses. During installation of the appliance, the installation technician should nonetheless check the correct setting of this value.

The regeneration of the resins is carried out by means of a special regeneration cycle with coarse salt, following the instructions described hereinafter.



#### IMPORTANT:

**Only use coarse salt with a purity level of 99.8% NaCl. The use of salt with a lower purity level can cause clogging of the salt container filter and malfunctioning of the water softener.**

When the message "REG" appears on the display,



activate the cycle to regenerate the resins:

- Open the salt container.

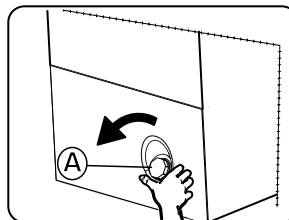

Figure 23

- Pour approximately 0.5 Kg of coarse salt (NaCl) (the amount necessary to fill the salt container up to the rim) into container "A".

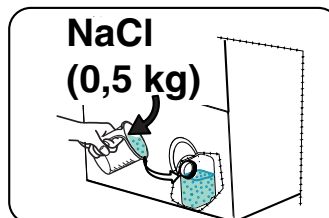

Figure 24



#### IMPORTANT:

**only salt may be placed in the salt container. Do not introduce any other chemical substances such as detergent, rinse aid or descaling agent, since these would inevitably damage the appliance. Such damage invalidates any warranty and relieves the manufacturer of all liability.**

- Remove any salt residue from around the salt container hole and screw the salt container top on again tightly.
- Open the door and remove the overflow "W".

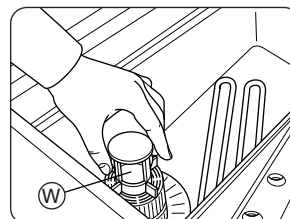



Figure 25

- Close the door.
- Start the regeneration cycle by pressing the button "G" (Figure 15) for at least 5 seconds.



#### IMPORTANT

**do not open the salt container during the entire regeneration cycle as the saline solution could spill out. During this process it is normal to hear a metallic sound for a short period.**

- During the regeneration cycle the display alternately blinks two symbols: “” and “”:

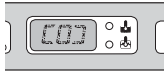

- After about 50 minutes, 3 beeps indicate the end of the regeneration cycle and “END” blinks on the display:

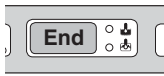

- Replace the overflow.
- Close the door.

The dishwasher is now ready to start the normal working functions.



**IMPORTANT**

**If the regeneration cycle is accidentally started, it can be switched off by pressing the button “G” (Figure 15) for at least 5 seconds.**

**IMPORTANT**

**The regeneration cycle is temporarily stopped:**

- in the event of a power failure,
- if the door is opened,
- if the machine is switched off.

**The cycle will be completed only when normal conditions are reinstated: the symbol “” and the symbol “” will flash alternately on the display.**

**C6 WARNING MESSAGES DISPLAYED ON THE CONTROL PANEL**

**A1 NO WATER**

- Check that the cock is open
- Check that the water inlet filter is clean
- Check the minimum mains pressure
- Check that the overflow pipe is inserted (for appliances without drain pump only).

**B1 INEFFICIENT DRAINAGE**

- Check if the overflow has been removed.
- Check for obstruction on the waste outlet pipe and the overflow aperture.

**B2 TANK WATER LEVEL TOO HIGH**

- Check for obstruction on the waste outlet pipe and the overflow aperture.

**C1..C8 CALL THE SERVICE CENTRE**

**E1..E8 CALL THE SERVICE CENTRE**

- The appliance continues to operate, but appropriate checks by a technician are recommended.

**C7 RESIDUAL RISKS**

The machine has several risks that were not completely eliminated from a design standpoint or with the installation of adequate protection devices.

Nevertheless, through this manual the Manufacturer has taken steps to inform operators of such risks, carefully indicating the personal protection equipment to be used by them.

Sufficient spaces are provided for during the machine installation phases in order to limit these risks.

To preserve these conditions, the corridors and areas around the machine must always be:

- kept free of obstacles (e.g. ladders, tools, containers, boxes, etc.);
- clean and dry;
- well lit.

For the Customer's complete information, the residual risks remaining on the machine are given below; such actions are to be considered incorrect and therefore strictly forbidden.

RESIDUAL RISK	DESCRIPTION OF HAZARDOUS SITUATION
Slipping or falling	The operator can slip due to water or dirt on the floor.
Burns	The operator deliberately or unintentionally touches some components inside the machine or dishes at the outfeed without using gloves or without allowing them to cool. Possible contact with water above 60°C / 140°F.
Electrocution	Contact with live parts during maintenance operations carried out with the electrical panel powered.
Falling from above	The operator intervenes on the machine using unsuitable systems to access the upper part (e.g. rung ladders, or climbs on it).
Tipping of loads	During maintenance on the machine or the packing containing the machine with the use of unsuitable accessories or lifting systems or with load unbalanced.
Chemical	Contact with chemical substances (e.g. detergent, rinse aid, scale remover, etc.) without taking adequate safety precautions. Therefore always refer to the safety cards and labels on the products used.

**D****TROUBLESHOOTING**

<b>DISHWASHER DOES NOT WASH WELL</b>	<ol style="list-style-type: none"><li>1. Check if the suction filter is dirty and clean it thoroughly.</li><li>2. Check if the wash jets are clogged by solid food remains.</li><li>3. Check that the initial amount of detergent or subsequent additions are correct.</li><li>4. The selected wash cycle is too short. Repeat the cycle.</li><li>5. Check that the tank temperature is between 55 °C and 65 °C.</li><li>6. Check that the dishes are stacked correctly in the racks.</li></ol>
<b>GLASSES AND DISHES ARE NOT DRIED PROPERLY</b>	<ol style="list-style-type: none"><li>1. Check the instructions for the amount of rinse-aid (see “setting the dispensers” paragraph).</li><li>2. Check that there is rinse-aid in the container and if necessary top up.</li><li>3. Check the set amount of rinse-aid (see “setting the dispensers” paragraph).</li><li>4. Check that the water temperature is between 80 °C and 90 °C.</li></ol>
<b>CONDENSATION ON GLASSES</b>	<ol style="list-style-type: none"><li>1. Check that there is rinse-aid in the container and if necessary top up.</li><li>2. Check the set amount of rinse-aid (see “setting the dispensers” paragraph).</li><li>3. Remove the rack of glasses immediately the cycle has ended.</li></ol>
<b>STAINS ON THE GLASSES</b>	<ol style="list-style-type: none"><li>1. Only use “non-foaming” products for professional dishwashers.</li></ol>
<b>EXCESSIVE FOAM IN THE TANK</b>	<ol style="list-style-type: none"><li>1. Check that the wash water temperature is not less than 50 °C.</li><li>2. Check if the amount of product dispensed by the detergent dispenser is excessive (see “setting the dispensers” paragraph).</li><li>3. Ensure that the tank has not been cleaned with unsuitable cleaners. Drain the tank and rinse thoroughly before new wash cycles.</li><li>4. If a foaming detergent has been used, drain and refill the tank with water until the foam disappears.</li></ol>
<b>SMEARS OR SPOTS ON THE GLASSES</b>	<ol style="list-style-type: none"><li>1. Reduce the amount of rinse-aid (see “setting the dispensers” paragraph).</li></ol>
<b>THE WASH OR RINSE ARMS TURN SLOWLY</b>	<ol style="list-style-type: none"><li>1. Remove and thoroughly clean the arms.</li><li>2. Clean the wash pump suction filter.</li></ol>