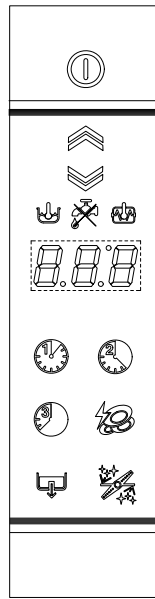
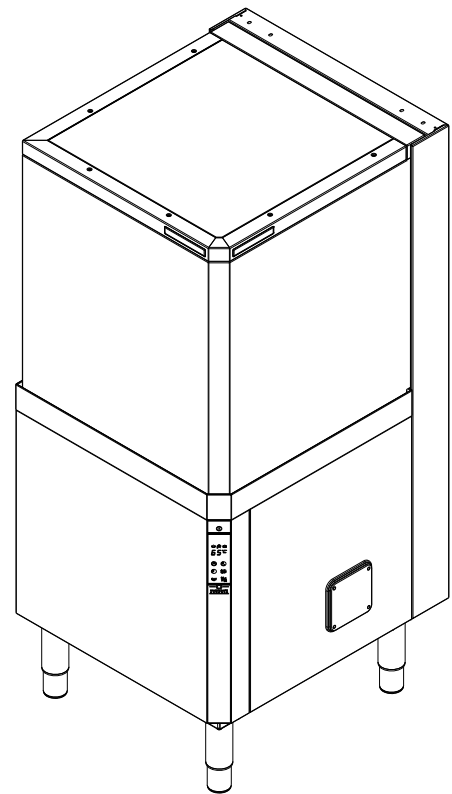
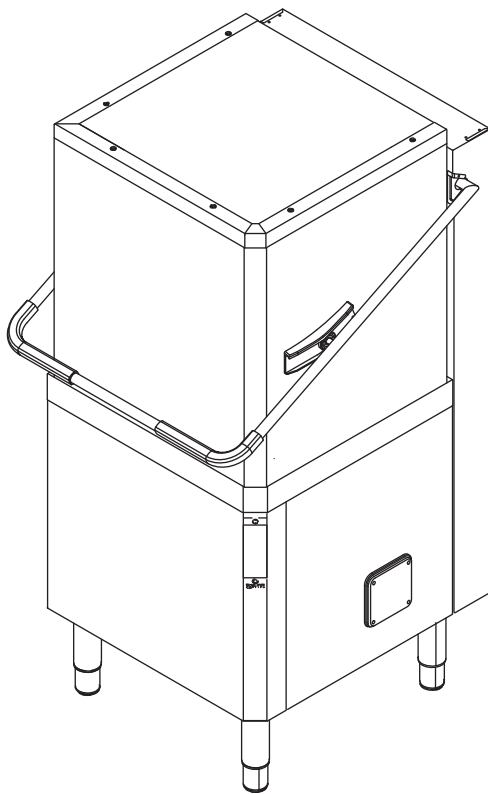




# SERVICE MANUAL



**CONTENTS:** This document contains the instructions to set electronic board parameters via user interface for following dishwashers:



**EDITION:** 10.2014

Updated to firmware version 0.30.

**WARNING:**

All the safety regulations and procedures to be followed by the Specialised Technician/Technical Assistance performing electrical, mechanical or electronic maintenance operations are contained in the instruction manual supplied with the machine: refer to this document before operating. This applies for anyone carrying out operations using these documents. The specialised technician must wear personal protection equipment suitable for the work being performed (e.g. gloves, safety glasses and shoes, suitable clothing, etc.) and use appropriate tools, equipment and auxiliary means.





## INDEX

1	KEYBOARDS	Pag.	4
1.1	DESCRIPTION OF CONTROL PANEL	Pag.	4
1.2	SERVICE/ MAINTENANCE COMMANDS	Pag.	4
2	USER INTERFACE CHECK	Pag.	5
3.1	DETERGENT DISPENSER ACTIVATION (depending on the model)	Pag.	5
3.2	RINSE AID DISPENSER ACTIVATION (depending on the model)	Pag.	5
4	RINSE PUMP MANUAL ACTIVATION	Pag.	6
5	ACCESSING THE PARAMETERS MENU	Pag.	6
6	<i>U5r</i> USER PARAMETERS	Pag.	8
6.1	<i>d,5</i> DISPENSERS PARAMETERS - DETERGENT AND RINSE AID DOSAGE	Pag.	8
6.1.1	Peristaltic tube fitting and replacement instructions	Pag.	10
6.2	<i>Ent</i> COUNTERS	Pag.	12
7	<i>FAL</i> FACTORY PARAMETERS	Pag.	14
7.1	<i>ba</i> BOILER PARAMETERS	Pag.	14
7.2	<i>tub</i> TANK PARAMETERS	Pag.	16
7.3	CYCLE SETTING	Pag.	17
7.3.1	Wash cycle diagram	Pag.	18
7.3.2	<i>[Y1]</i> Cycle 1 parameters	Pag.	19
7.3.3	<i>[Y2]</i> Cycle 2 parameters	Pag.	19
7.3.4	<i>[Y3]</i> Cycle 3 parameters	Pag.	19
7.3.5	<i>drn</i> Drain/Cleaning cycle parameters	Pag.	19
7.4	OTHER PARAMETERS	Pag.	21
7.4.1	<i>dPR</i> Dishwashing parameters	Pag.	22
7.4.2	<i>ron</i> Read Only parameters	Pag.	22
7.4.3	<i>HCP</i> Communication and HACCP parameters	Pag.	22
7.4.4	<i>FCU</i> Configuration parameters	Pag.	23
7.4.5	<i>dLP</i> Delime cycle parameters (Delime)	Pag.	24
7.4.6	DELIME DISPENSER ACTIVATION	Pag.	26
7.4.8	<i>RSa</i> Water softener parameters	Pag.	27
8	DEFAULT VALUES	Pag.	28
9	MAIN BOARD CONFIGURATION	Pag.	29
9.1	CODE -> Prog. TABLE	Pag.	29
9.2	PROGRAMMING SHEETS	Pag.	30
9.3	USER INTERFACE AND MAIN BOARD CONNECTORS	Pag.	36
9.3.1	Connectors layout	Pag.	36
10	DISHWASHER SETTING IN PREWASH MODE	Pag.	37
11.1	MAIN MALFUNCTIONS NOT DUE TO THE MAIN BOARD	Pag.	37
11.2	ALARMS THAT STOP THE DISHWASHER	Pag.	37
11.2.1	Alarm codes for automatic hood type dishwashers	Pag.	38
11.3	ALARMS THAT DON'T STOP THE DISHWASHER	Pag.	39

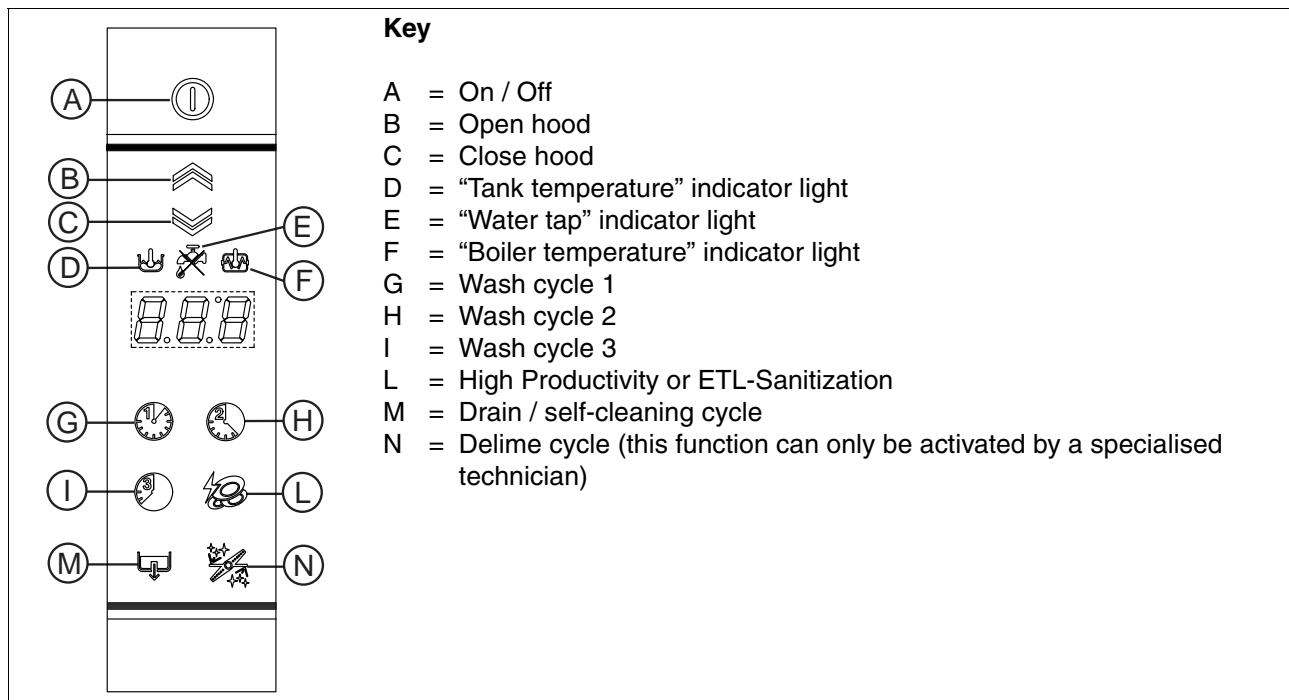
## INDEX OF FIGURES AND TABLES

Table 1	ACCESSING THE PARAMETERS MENU	Pag.	7
Table 2	ACCESSING THE DISPENSERS PARAMETERS	Pag.	9
Table 3	ACCESSING THE COUNTERS	Pag.	13
Table 4	ACCESSING THE BOILER PARAMETERS	Pag.	15
Table 5	ACCESSING THE TANK PARAMETERS	Pag.	17
Table 6	ACCESSING THE CYCLE PARAMETRS	Pag.	20

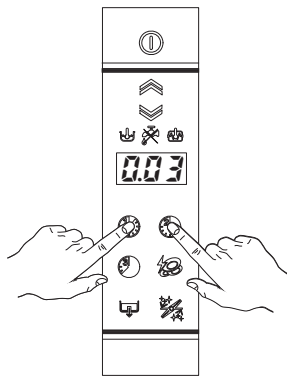


# 1 KEYBOARDS

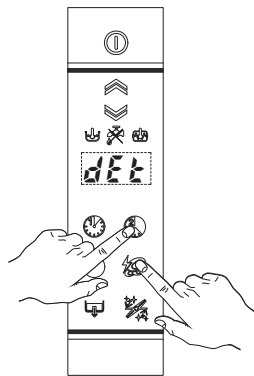
## 1.1 DESCRIPTION OF CONTROL PANEL



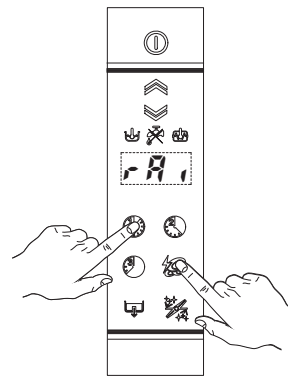
## 1.2 SERVICE/ MAINTENANCE COMMANDS



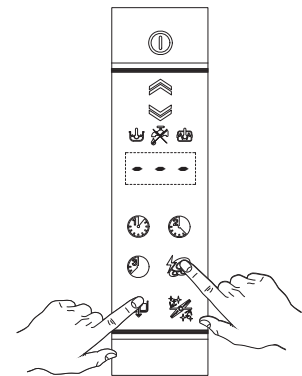
**Fig. 1** User Interface check [§ 2]



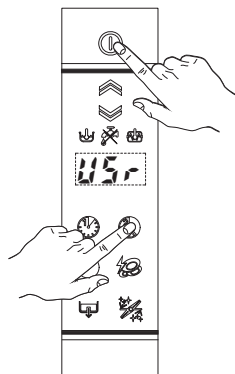
**Fig. 2** Detergent dispenser Manual Activation [§ 3.1]



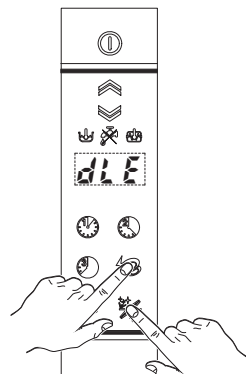
**Fig. 3** Rinse Aid Dispenser Manual Activation [§ 3.2]



**Fig. 4** Rinse Pump Manual Activation (used to EMPTY BOILER) [§ 4]



**Fig. 5** Accessing the parameters menu [§ 5]

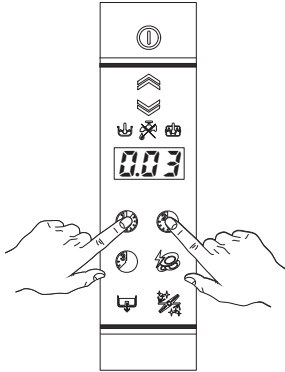


**Fig. 6** Delime Activation [§ 7.4.6]



## 2 USER INTERFACE CHECK

This check allows you to verify if the USER INTERFACE board works properly.

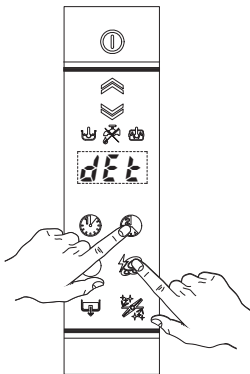


1. Activate the dishwasher
2. Press at the same time the washing cycle 1 and the washing cycle 2 ("G" - "H" Par. 1.1 DESCRIPTION OF CONTROL PANEL), the display shows the firmware version of the user interface board (example: **003**)
3. To check if the display works properly, press at the same time the washing cycle 1 and the washing cycle 2, the display shows all the elements that are on (**000**).
4. To check if the buttons and pilot light work properly, press at the same time washing cycle 1 and washing cycle 2. Press the buttons one by one to check them. An acoustic signal confirms that the button work properly.

## 3 MANUAL ACTIVATION OF DETERGENT AND RINSE AID DISPENSERS

When replacing detergents may be necessary activate the dispensers to fill hoses.

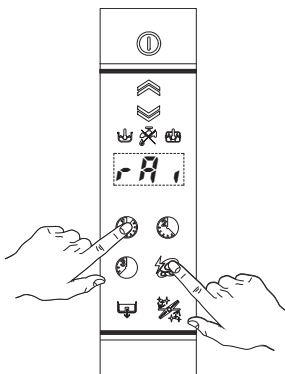
### 3.1 DETERGENT DISPENSER ACTIVATION (depending on the model)



Switch on the dishwasher.

Press and hold down wash cycle 2 ("H" - Par. 1.1 DESCRIPTION OF CONTROL PANEL) and "L" key (Par. 1.1 DESCRIPTION OF CONTROL PANEL), after two 'beep' the detergent dispenser starts work for 20 sec.

### 3.2 RINSE AID DISPENSER ACTIVATION (depending on the model)



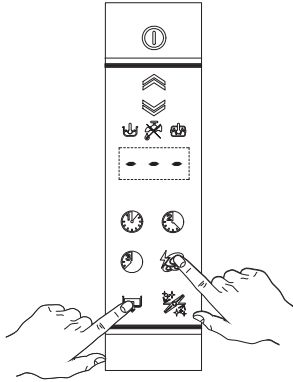
Switch on the dishwasher.

Press and hold down wash cycle 1 ("G" - Par. 1.1 DESCRIPTION OF CONTROL PANEL) and "L" key (Par. 1.1 DESCRIPTION OF CONTROL PANEL), after two 'beep' the rinse aid dispenser starts work for 40 sec.



## 4 RINSE PUMP MANUAL ACTIVATION

Use this function to empty the boiler (if the dishwasher is not to be used for a long time, for maintenance operation: ex. before replacing main board).



Switch on the dishwasher.

Close the door and press and hold down Drain / self-cleaning cycle ("M" - Par. 1.1 DESCRIPTION OF CONTROL PANEL) and "L" key (Par. 1.1 DESCRIPTION OF CONTROL PANEL). A buzzer signal indicates the rinse pump activation and the display shows three blinking lines. Three beeps indicate the cycle end.

## 5 ACCESSING THE PARAMETERS MENU

The parameters are divided into two families: *USR* user parameters and *FRE* factory parameters.

In the *USR* family there are parameters for adjusting the detergent and rinse aid dispensers and the counters (wash cycles, drain/cleaning cycles, etc. ).

In the *FRE* family there are all parameters that determine dishwasher operation: boiler and tank working temperature, duration of the phases of each cycle, etc.

To access the parameters menu, the unit must be in standby mode: switch on the unit and check that no cycles are selected. In the programming phase it is advisable to keep the hood open to avoid starting a cycle if the two buttons are not pressed together (see point 2 in the following example).

Example:

With reference to Table 1 ACCESSING THE PARAMETERS MENU assuming the boiler temperature parameter *bte* is to be modified.

1. Switch the dishwasher off and then on again;
2. Enter the parameter mode by pressing and holding down the On/ff buttons ("A" - Par. 1.1 DESCRIPTION OF CONTROL PANEL) and wash cycle 2 ("H" - 1.1 DESCRIPTION OF CONTROL PANEL) for approx. 5 sec. The display shows the message *USR*;
3. Press the wash cycle 2 ("H" - Par. 1.1 DESCRIPTION OF CONTROL PANEL) button to go to the *FRE* family;
4. Press the button ("L" - 1.1 DESCRIPTION OF CONTROL PANEL) to access the boiler parameters *b a r* family;
5. Press the button ("L" - Par. 1.1 DESCRIPTION OF CONTROL PANEL) again to display the boiler temperature parameter *bte*;
6. Press the button ("L" - Par. 1.1 DESCRIPTION OF CONTROL PANEL) again to display the boiler temperature parameter value;
7. Use wash cycle 1 ("G" - Par. 1.1 DESCRIPTION OF CONTROL PANEL) and wash cycle 2 ("H" - Par. 1.1 DESCRIPTION OF CONTROL PANEL) to modify the parameter value; use the wash cycle 1 button to decrease the value and the wash cycle 2 button to increase it;  
NOTE: If the tank LED is on, the parameter value corresponds to the factory-set value.
8. Press the button ("L" - Par. 1.1 DESCRIPTION OF CONTROL PANEL) to confirm the value and return to the display of parameters.  
NOTE: To exit the parameter mode and return to the display of the families, press wash cycle 3 ("I" - Par. 1.1 DESCRIPTION OF CONTROL PANEL).

Similarly it is possible to change the other values; afterwards, switch the machine off and then on again.

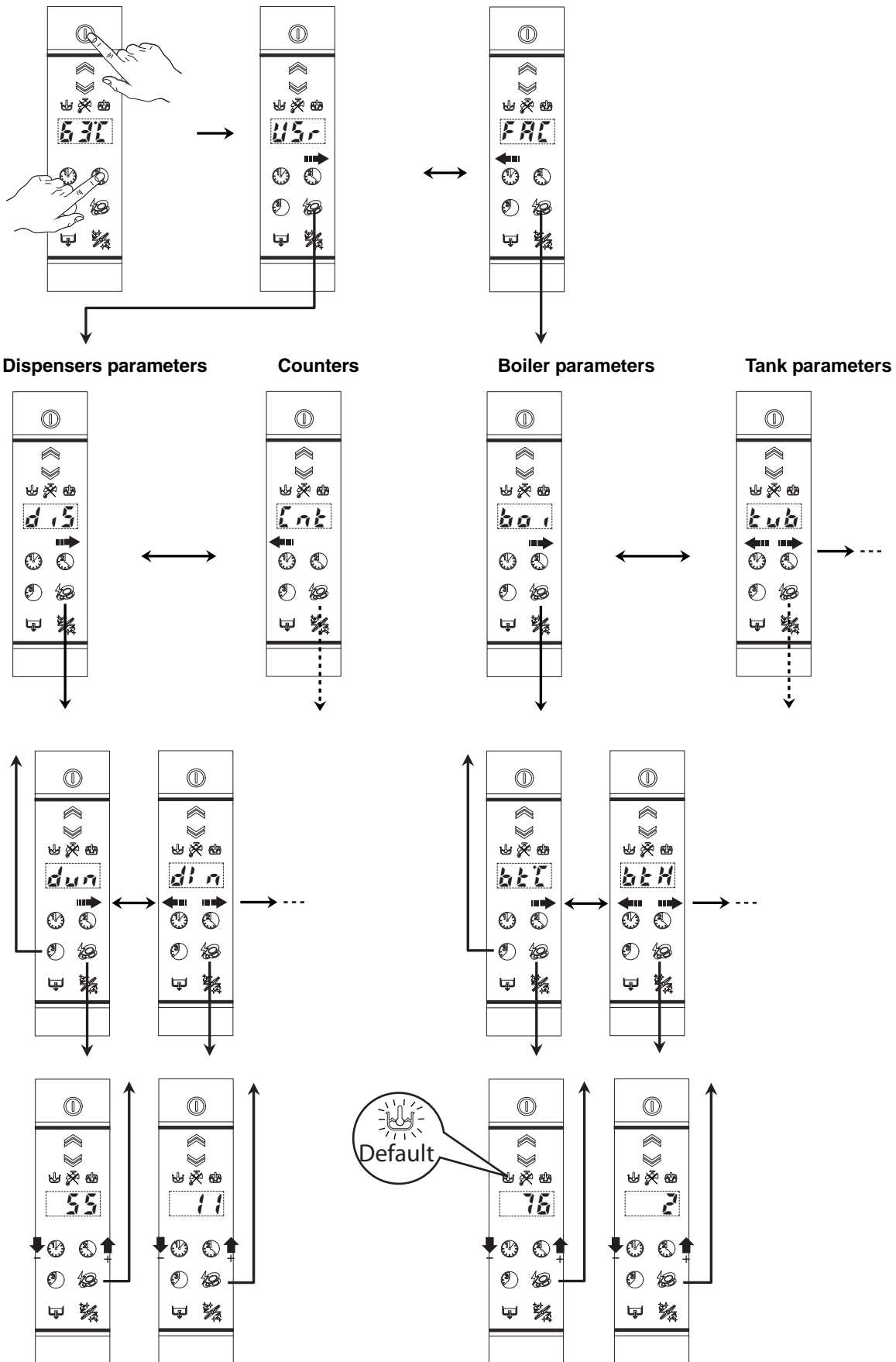


**Table 1 ACCESSING THE PARAMETERS MENU**

(keep the buttons pressed for approx. 5 sec.)

**User parameters**

**Factory parameters**





## 6 USER PARAMETERS

### 6.1 DISPENSERS PARAMETERS - DETERGENT AND RINSE AID DOSAGE

In this paragraph is explained how to set the dosage for the detergent and rinse aid dispensers. For each dispenser there are two parameters: the initial dosage and the dosage during cycle execution.

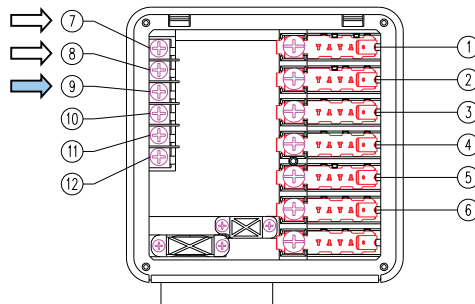
By changing the *dur* parameter is possible to set the desired unit of measure (*g/l* or *seconds*). If *dur = g/l* need to set the parameters on the concentration in g/l, while if *dur = seconds* parameters correspond to the activation times in seconds.

Sym.	Parameter Description	Unit	Min	Max	Factory Default
<i>dur</i>	Dispensers unit of measure ( <i>g/l</i> or <i>seconds</i> )	-	-	-	<i>g/l</i>
<i>dln</i>	Initial Detergent Dosage (during filling tank)	[g/l]	0	4,00	2,00
		[s]	0	240	55
<i>rin</i>	Initial Rinse Aid Dosage (starts when tank filled)	[g/l]	0	1,00	0,12
		[s]	0	180	11
<i>det</i>	Detergent Dosage During Cycle Execution (during wash phase)	[g/l]	0	4,00	2,00
		[s]	0	182 (*)	5
<i>rai</i>	Rinse Aid Dosage During Cycle Execution (when refilling boiler)	[g/l]	0	1,00	0,12
		[s]	0	62 (*)	2

#### (\*) Note for external dispensers (if: *dur = seconds*):

- if *det = 101* the **detergent dispenser** works when **WASHING PUMP** is being activated; at the same time voltage is supplied between connectors **L17-L19** (main terminal box);
- if *det = 102* the **detergent dispenser** works when **LOADING EV** is being activated to re-fill boiler level; at the same time voltage is supplied between connectors **L17-L19** (main terminal box);
- if *rai = 61* the **rinse aid dispenser** works when **LOADING EV** is being activated to re-fill boiler level; at the same time voltage is supplied between connectors **L18-L19** (main terminal box);
- if *rai = 62* the **rinse aid dispenser** works when **WASHING PUMP** is being activated; at the same time voltage is supplied between connectors **L18-L19** (main terminal box).

- For electrical connections refer to electric diagram



#### Example

Suppose there is connected an **external detergent dispenser** with a probe into the tank.

A typical setting could be:

- *dln = 0* the dispenser is not activated during filling tank;
- *det = 101* the dispenser is supplied during washing phase and the probe automatically dose the right detergent amount.

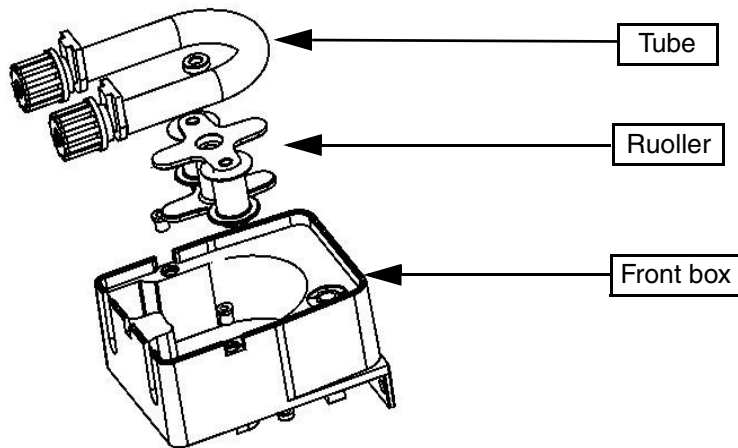




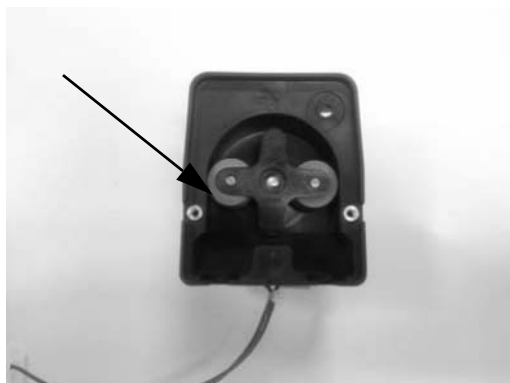
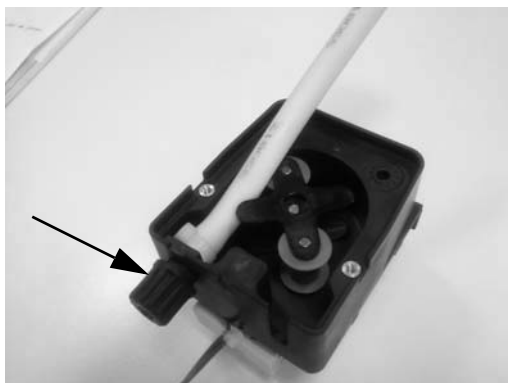
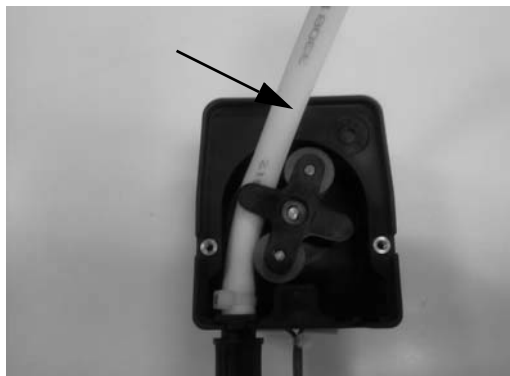
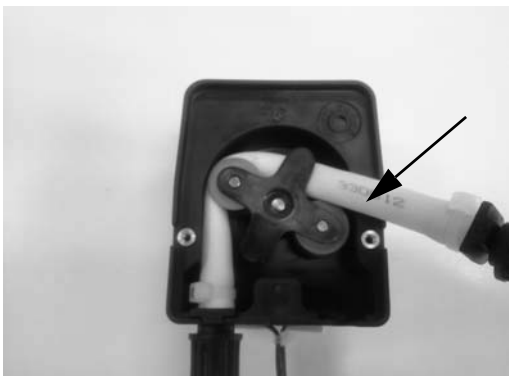
### 6.1.1 Peristaltic tube fitting and replacement instructions

Described below is the procedure for inserting and removing the tubes from the peristaltic pumps, in case of tube replacement.

An exploded view of the parts involved in the tube fitting and removal operations is given below.



#### STEP 1 - FITTING THE TUBE

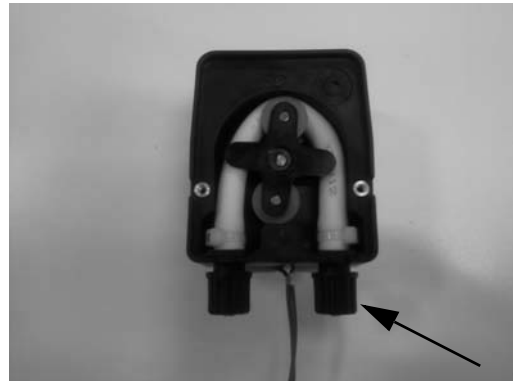
1. Position the roller.	2. Insert the tube of the suction part, turning the roller clockwise.
	
3. Keep the tube in the seat in the housing and continue turning the roller clockwise, <u>being careful not to damage the tube.</u>	4. Keep the tube in the seat in the housing and continue turning the roller clockwise.
	



5. Turn the roller a full 360°.

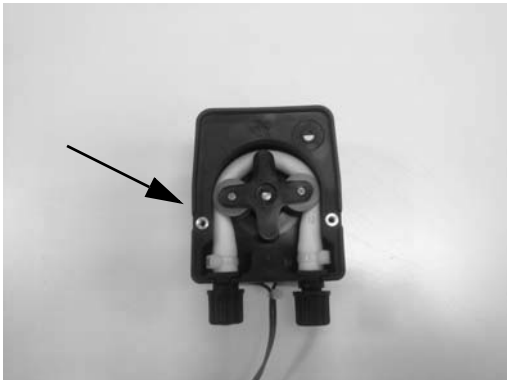


6. Make sure to fit the union in the special seat (delivery).

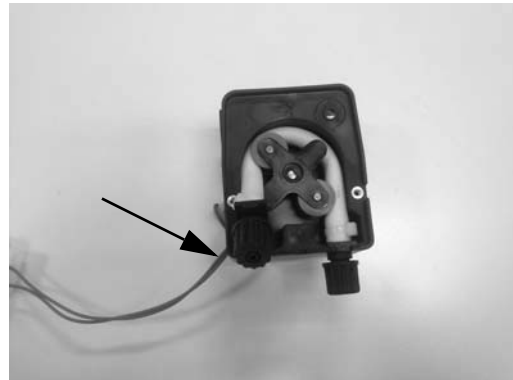


### STEP 2 - REMOVING THE TUBE

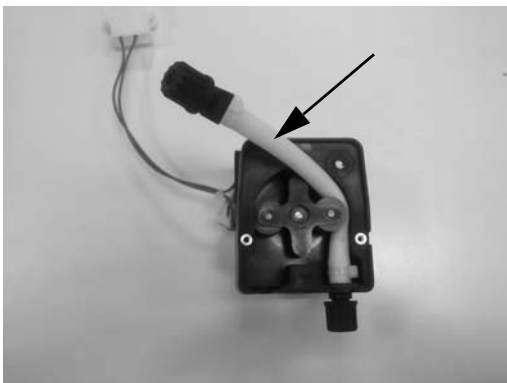
1. Position the roller as shown in the figure.



2. Lift the tube at the suction part and turn the roller at the same time. Guide the tube, keeping it raised, and turn the roller.



3. Remove the tube.





## 6.2 **Count** COUNTERS

This Parameter Family collects cycle counters and water consumption counters.

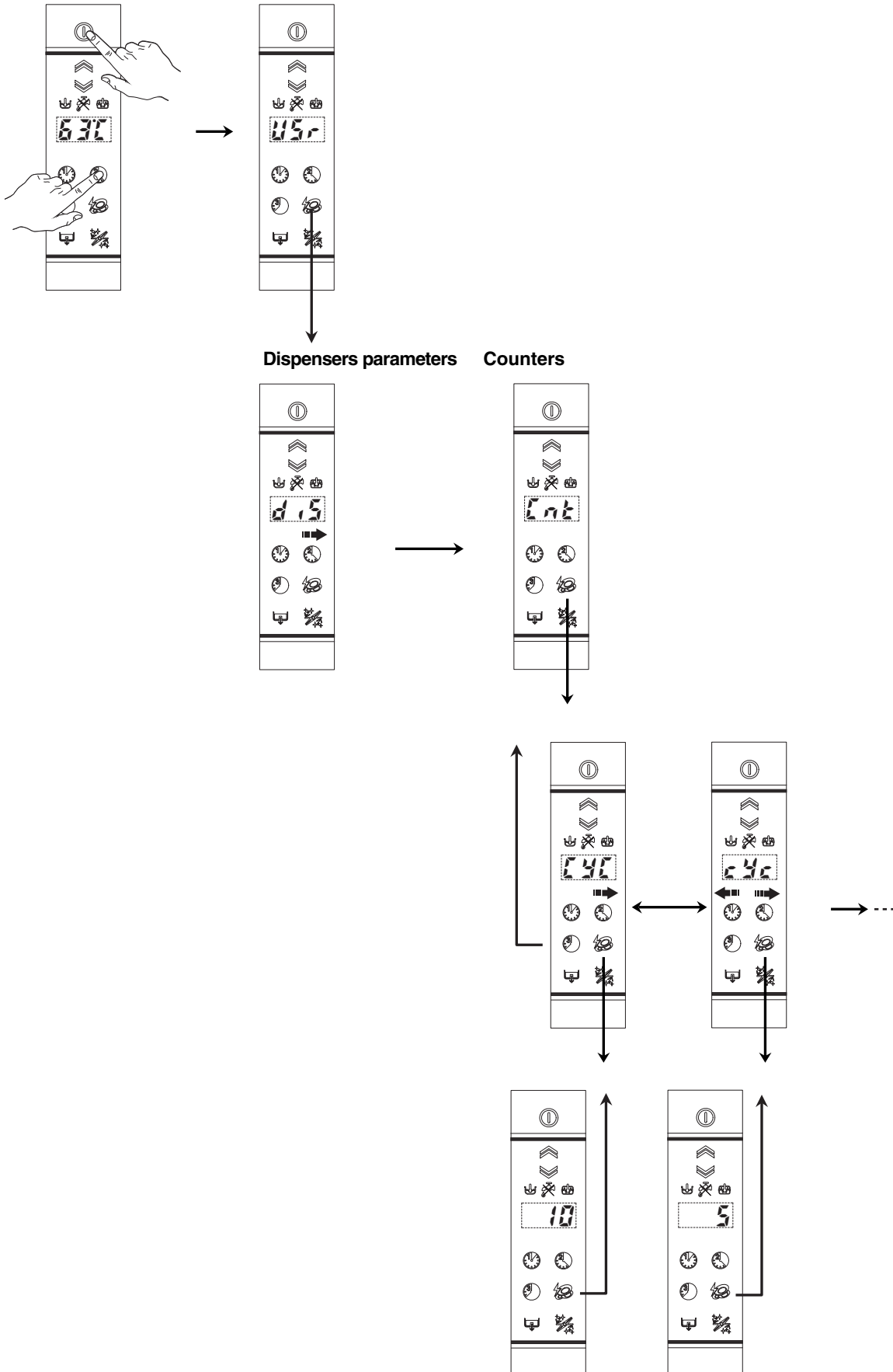
For water consumption counters a flow meter must be installed. See **PPL** (calibration parameter) into **dPA** section (7.4 OTHER PARAMETERS).

Sym.	Parameter Description	Unit	Min	Max	Factory Default
<b>CYC</b>	Performed total cycles (counter is NOT resettable by the user).	-	-	-	-
<b>cyc</b>	Performed cycles (partial counter is resettable by user via the " <b>rSt</b> " parameter).	-	-	-	-
<b>m3c</b>	Counts m <sup>3</sup> of water consumption (counter is NOT resettable by the user). Works only if the flow meter is installed (integrated in the air gap for machines with watersoftener).	-	-	-	-
<b>L</b>	Counts liters of water consumption (counter is NOT resettable by the user). Works only if the flow meter is installed (integrated in the air gap for machines with watersoftener). Together with " <b>m3c</b> " parameter (m <sup>3</sup> ), This parameter gives the total water consumption of the machine.	[l]	-	-	-
<b>Lit</b>	Litres counters Counts the litres of water and is resettable by user (see <b>rSt</b> parameter below). Works only if the flow meter is installed (integrated in the air gap for machines with water softener).	[l]	-	-	-
<b>rSt</b>	Parameter to reset together counters: <b>cyc</b> and <b>Lit</b> . To reset put 1 this parameter, switch off and then on again: <b>cyc</b> and <b>Lit</b> will show zero.	-	-	-	-
<b>drc</b>	Drain/Cleaning cycles performed. Similar to <b>CYC</b> but counts Cleaning Cycles.	-	-	-	-
<b>dLc</b>	Delime cycles counter.	-	-	-	-
<b>cLd</b>	Number of executed washing cycles after last Delime cycle. This counter is reset after each Delime cycle.	-	-	-	-



**Table 3** ACCESSING THE COUNTERS

(keep the buttons pressed for approx. 5 sec.)





## 7 FAE FACTORY PARAMETERS

In this paragraph is explained how to change temperature thresholds and all parameters related to boiler and tank.

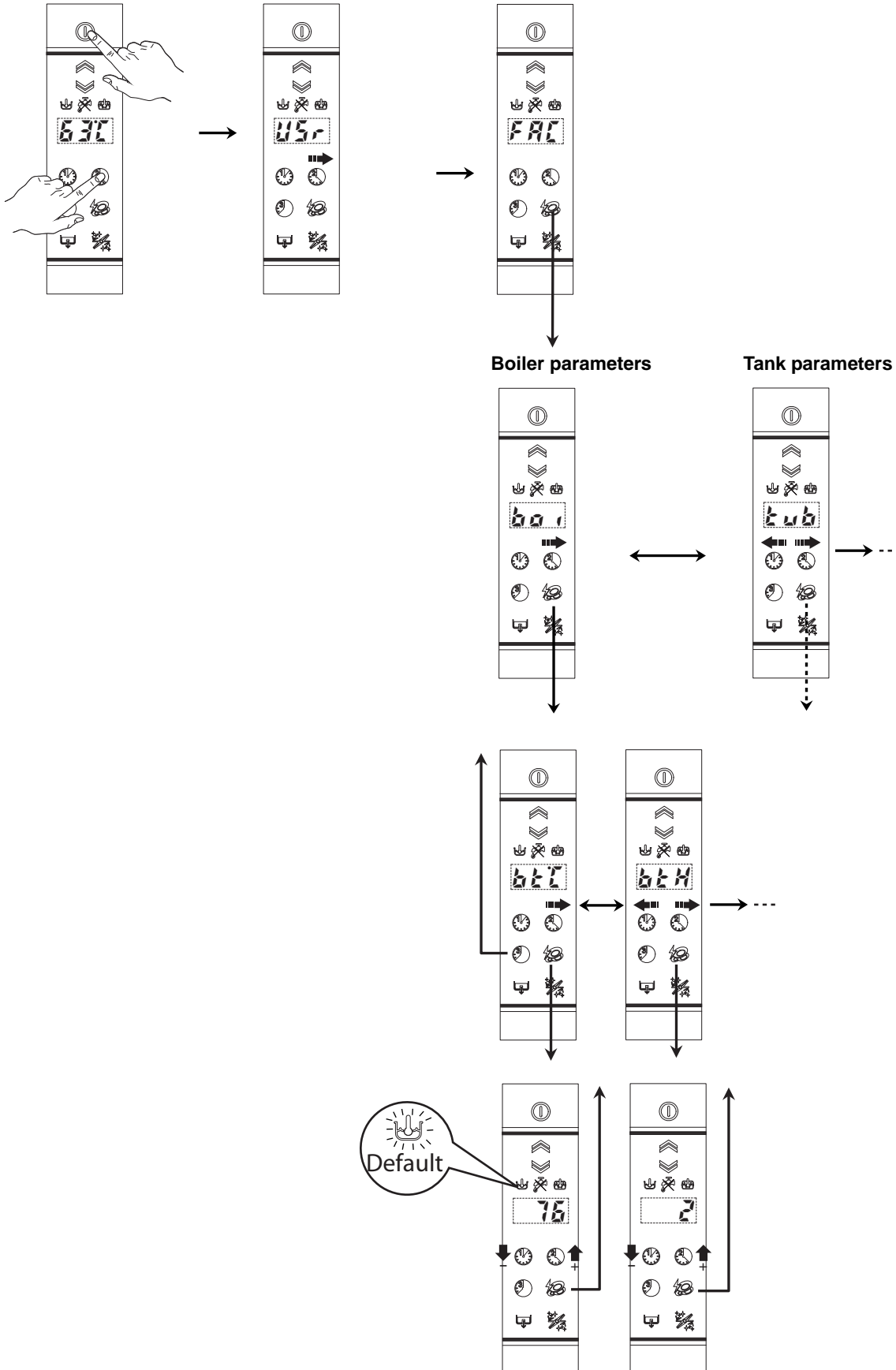
### 7.1 boiler BOILER PARAMETERS

Sym.	Parameter Description	Unit	Min	Max	Factory Default
<b>bte</b>	Boiler Temperature: THRESHOLD. When boiler temperature reaches this value, heaters switch off. If the threshold value is set to the minimum value (44) the heaters of the boiler are off and the thermo-stating is not active.	[°C]	44	95	78
<b>bth</b>	Boiler Temperature HISTERESIS, (represent dead band). Heater switch on if boiler temperature is below: <b>bte</b> - <b>bth</b>	[°C]	2	10	2
<b>bhl</b>	Boiler Temperature: HIGH LIMIT. When boiler temperature reaches this value <b>h2</b> alarm appears. Put 0 to disable <b>h2</b> alarm.	[°C]	0	98	96
<b>blo</b>	Boiler Temperature: LOW LIMIT. During boiler warm-up, temperature must increase at least <b>blo</b> °C otherwise <b>e3</b> warning appears. Put 0 to disable <b>e3</b> warning.	[°C]	0	10	1
<b>bfl</b>	Boiler Filling Timeout. If filling time is longer than <b>bfl</b> , <b>h1</b> alarm appears. Put 0 to disable <b>h1</b> alarm.	[min]	0	42	5
<b>bad</b>	Boiler Temperature Adjust.	[°C]	0	7	4
<b>bp</b>	Boiler Priority (enable boiler wait function) 0= <b>no</b> = disabled 1= <b>yes</b> = enabled	-	<b>no</b>	<b>yes</b>	<b>yes</b>
<b>bst</b>	Boiler Function Overheat gap over Boiler Temperature Threshold	[°C]	0	15	2
<b>btd</b>	Boiler temperature negative differential: when the dishwasher is in standby, boiler threshold becomes: <b>bte</b> - <b>btd</b> (Used to save energy during machine inactivity by keeping boiler water at a lower temperature).	[°C]	0	20	0
<b>bpo</b>	Boiler heating control. Defines the max. permissible temperature difference during boiler heating in a time interval of 2 minutes and 30 seconds. If in this period of time, the temperature increases over <b>bpo</b> appears the alarm <b>h1</b> .	[°C]	25	80	50
<b>bpu</b>	Boiler power: 0 = <b>lo</b> = Low power (only two branches of the three-phase heating element are used for boiler heating) 1 = <b>hi</b> = Maximum power (all branches of the three-phase heating element are used for boiler heating)	-	<b>lo</b>	<b>hi</b>	<b>hi</b>
<b>btl</b>	Boiler temperature in mode Thermal Label.	[°C]	45	97	86



**Table 4** ACCESSING THE BOILER PARAMETERS

(keep the buttons pressed for approx. 5 sec.)





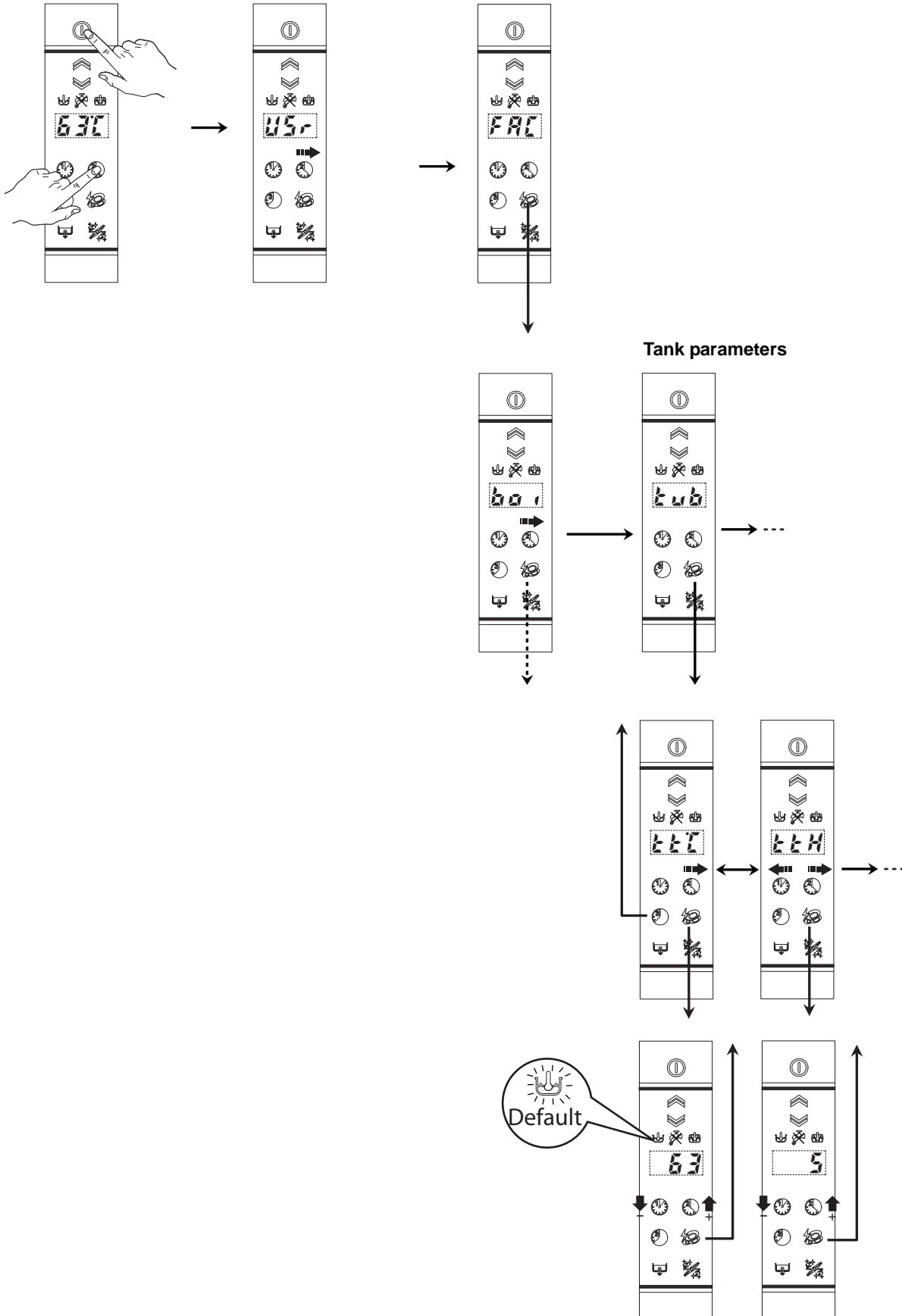
## 7.2 *tub* TANK PARAMETERS

Sym.	Parameter Description	Unit	Min	Max	Factory Default
<i>t t t</i>	Tub Temperature: THRESHOLD When tank temperature reaches this value, heater switch off. If the threshold value is set to the minimum value (39) the heater of the tank is off and the thermo-stating is not active.	[°C]	39	85	63
<i>t t H</i>	Tub Temperature: HISTERESIS, (represent dead band). Heater switch on if tank temperature is below: <i>t t t</i> - <i>t t H</i>	[°C]	2	30	5
<i>t H ,</i>	Tank Temperature: HIGH LIMIT. When tank temperature reaches this value <i>t H ,</i> alarm appears. Put 0 to disable <i>t H ,</i> alarm.	[°C]	0	95	85
<i>t t o</i>	Tank Temperature: LOW LIMIT. During tank warm-up, temperature must increase at least <i>t t o</i> °C otherwise <i>t t o</i> warning appears. Put 0 to disable <i>t t o</i> warning.	[°C]	0	10	1
<i>t F L</i>	Tank Filling Timeout. If filling time is longer than <i>t F L</i> , <i>A 1</i> alarm appears. Put 0 to disable <i>A 1</i> alarm.	[min]	0	42	20
<i>L 1</i>	Tank filling level.	[mmH2O]	50	200	100
<i>L 1 H</i>	Hysteresis relevant to the filling level.	[mmH2O]	10	100	65
<i>L 2</i>	Overflow.	[mmH2O]	50	200	180
<i>L 2 H</i>	Hysteresis relevant to the overflow level.	[mmH2O]	10	100	60
<i>L d r</i>	Level (relevant to filling level <i>L 1</i> ) used in the drain phase during the cycle, that occurs after the wash phase.	[mmH2O]	2	20	8
<i>c y d</i>	Cycles to perform before a tank partial drain. If <i>c y d</i> is 0, the function is disable. If the function is enabled, the partial drain is performed in according with <i>L P d</i> and <i>P P d</i> parameters (described below).	-	0	50	0
<i>L P d</i>	Tank partial drain level	[mmH2O]	0	40	20
<i>P P d</i>	Increase the pause (between wash and rinse) when there is a tank partial drain.	[s]	0	16	6
<i>t t L</i>	Tank temperature in mode Thermal Label.	[°C]	40	90	75
<i>t H L</i>	Tank temperature hysteresis in mode Thermal Label.	[°C]	0	30	2



**Table 5 ACCESSING THE TANK PARAMETERS**

(keep the buttons pressed for approx. 5 sec.)

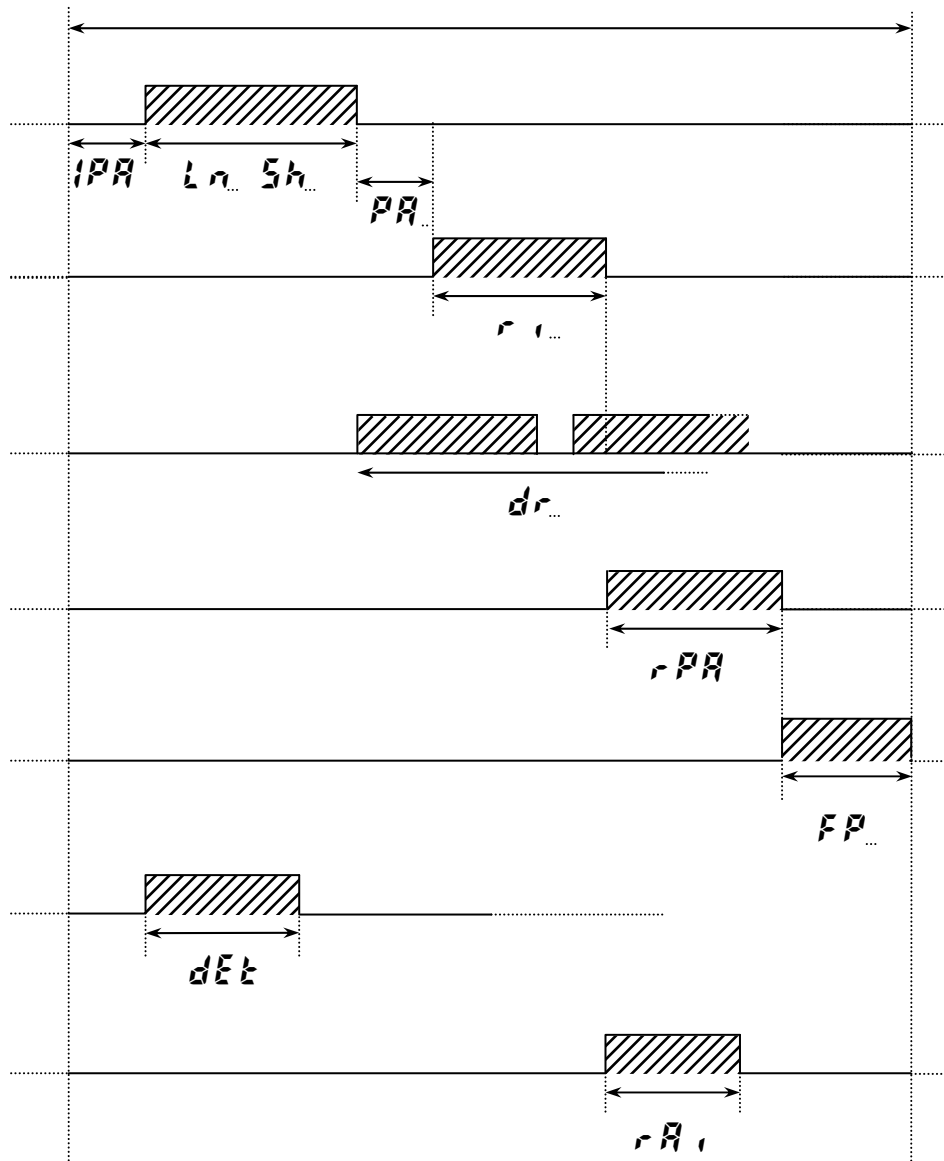


**7.3 CYCLE SETTING**



7.3.1 Wash cycle diagram

CYCLE TYME



KEY:

- IPA** = initial pause
- Ln Sh** = wash [the duration is given by the sum of the two parameters Ln(min) and Sh(sec)].
- PA** = final pause
- ri** = rinse
- dr** = drain
- rPA** = rinse pause
- dEt** = detergent
- rAi** = rinse aid

**Attention:** It does not necessarily correspond to activation of the drain pump; activation of this pump is a function of the tank level.



### 7.3.2 **[Y1]** Cycle 1 parameters

Sym.	Parameter Description	Unit	Min	Max	Factory Default
<b>Ln1</b>	Wash Phase Long	[min]	0	20	0
<b>Sh1</b>	Wash Phase Short	[s]	1	60	33
<b>PA1</b>	Pause	[s]	0	20	4
<b>r11</b>	Rinse Phase Duration	[s]	10	45	8
<b>dr1</b>	Drain	[s]	0	40	12
<b>FP1</b>	Final Pause at End of Cycle	[s]	0	60	0
<b>tL1</b>	Long wash time in mode Thermal Label	[min]	0	60	0
<b>tS1</b>	Short wash time in mode Thermal Label	[s]	0	60	45

### 7.3.3 **[Y2]** Cycle 2 parameters

Sym.	Parameter Description	Unit	Min	Max	Factory Default
<b>Ln2</b>	Wash Phase Long	[min]	0	20	1
<b>Sh2</b>	Wash Phase Short	[s]	1	60	12
<b>PA2</b>	Pause	[s]	0	20	4
<b>r12</b>	Rinse Phase Duration	[s]	10	45	8
<b>dr2</b>	Drain	[s]	0	40	12
<b>FP2</b>	Final Pause at End of Cycle	[s]	0	60	0
<b>tL2</b>	Long wash time in mode Thermal Label	[min]	0	60	1
<b>tS2</b>	Short wash time in mode Thermal Label	[s]	0	60	12

### 7.3.4 **[Y3]** Cycle 3 parameters

Sym.	Parameter Description	Unit	Min	Max	Factory Default
<b>Ln3</b>	Wash Phase Long	[min]	0	20	2
<b>Sh3</b>	Wash Phase Short	[s]	1	60	18
<b>PA3</b>	Pause	[s]	0	20	4
<b>r13</b>	Rinse Phase Duration	[s]	10	45	8
<b>dr3</b>	Drain	[s]	0	40	12
<b>FP3</b>	Final Pause at End of Cycle	[s]	0	60	0
<b>tL3</b>	Long wash time in mode Thermal Label	[min]	0	60	2
<b>tS3</b>	Short wash time in mode Thermal Label	[s]	0	60	18
<b>bt3</b>	Boiler Temperature Threshold: only for Cycle 3. This parameter allows having a different rinsing temperature for the third cycle. Only values above 45°C are allowed.	[°C]	0	95	0

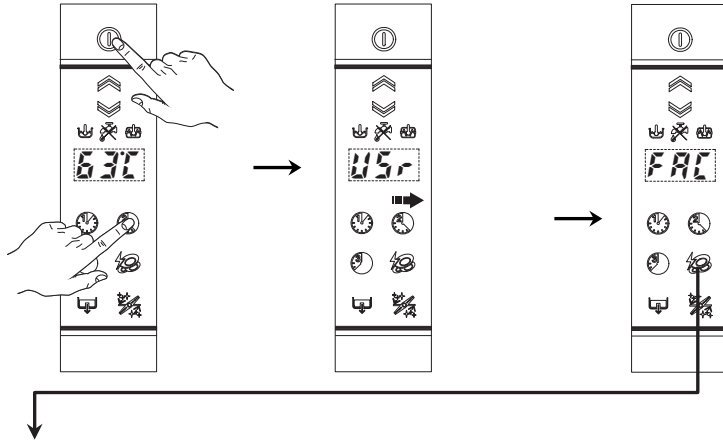
### 7.3.5 **drn** Drain/Cleaning cycle parameters

Sym.	Parameter Description	Unit	Min	Max	Factory Default
<b>ldr</b>	Initial Drain Phase Duration	[s]	0	240	40
<b>fdr</b>	Final Drain Phase Duration	[s]	0	240	80
<b>drb</b>	Drain without cleaning cycle	-	0	1	0

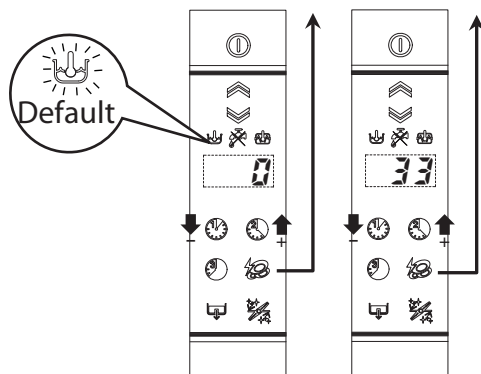
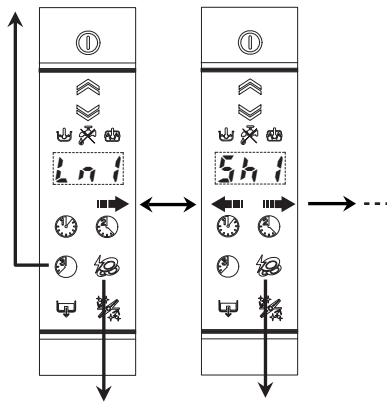
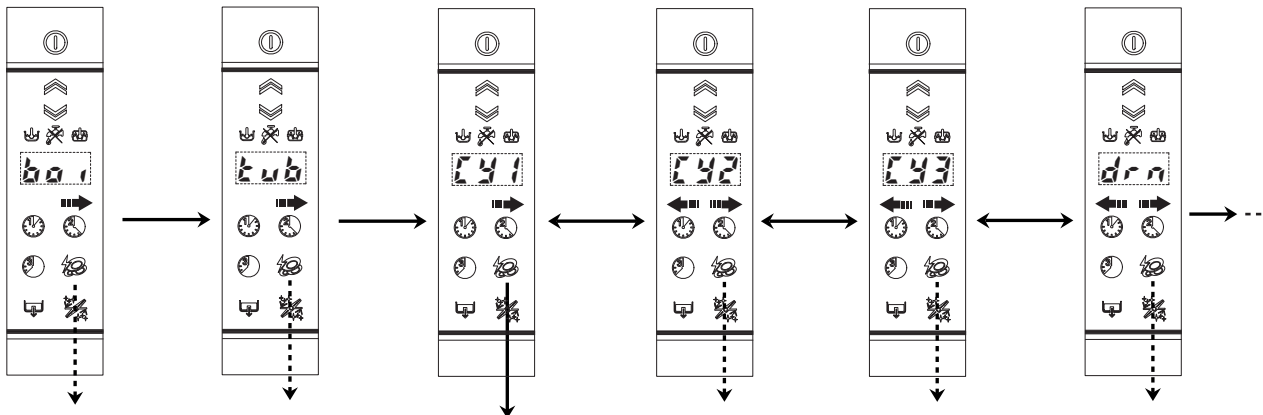


**Table 6 ACCESSING THE CYCLE PARAMETRS**

(keep the buttons pressed for approx. 5 sec.)



**Cycle 1 parameters    Cycle 2 parameters    Cycle 3 parameters    Drain parameters**

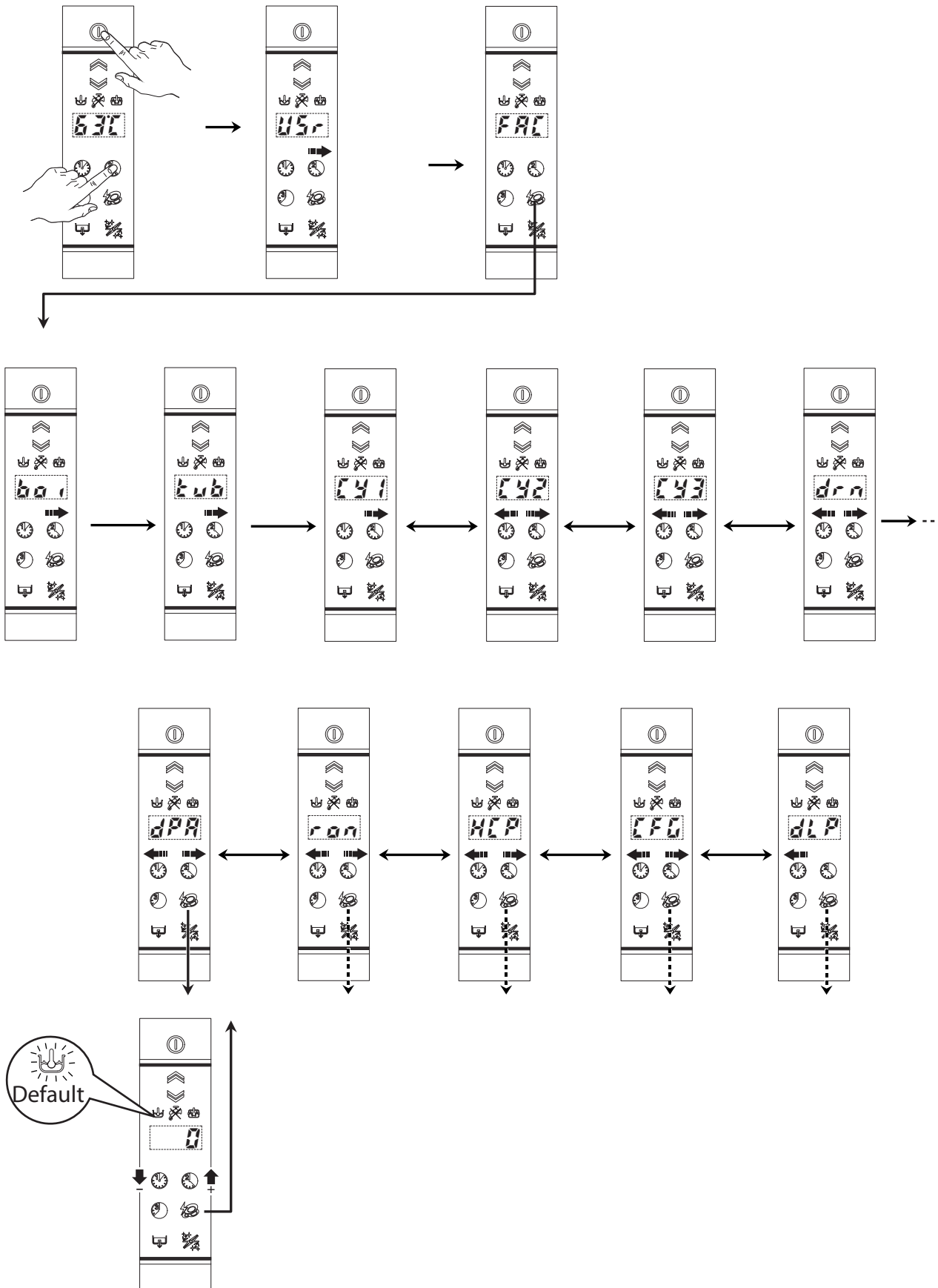




## 7.4 OTHER PARAMETERS

You can find the parameters families listed in the below table after the cycle parameters.

**Tabella 7: ACCESSO AD ALTRI PARAMETRI**  
(tener premuto i pulsanti per ca. 5 sec.)





### 7.4.1 **dPA** Dishwashing parameters

Sym.	Parameter Description	Unit	Min	Max	Factory Default
<b>IPR</b>	Initial Pause before start washing (for ALL cycles)	[s]	0	10	0
<b>Pdr</b>	Active a drain phase at the end of washing phase.	[s]	0	40	0
<b>rPR</b>	Duration of pause after rinse cycle (valid for dishwashers with door/hood lock device).	[s]	0	60	0
<b>[ F</b>	Celsius/Fahrenheit selection <b>[</b> = Celsius <b>F</b> = Fahrenheit	-	<b>[</b>	<b>F</b>	<b>[</b>
<b>r t</b>	Rinse Temperature Display. Enable rinse temperature probe (if installed). 0 = no = during rinse phase the display shows boiler temperature; 1 = YES = during rinse phase the display shows rinse temperature.	-	<b>no</b>	<b>YES</b>	<b>no</b>

### 7.4.2 **rOR** Read Only parameters

Sym.	Parameter Description	Unit	Min	Max	Factory Default
<b>[R1]</b>	When <b>[R1]</b> message appears, the parameter value becomes 3. After maintenance, to clear <b>[R1]</b> message, insert 0.	-	-	-	0
<b>[9]</b>	This parameter indicates the alarm code of an automatic hood-type dishwasher. See the complete list of alarm codes in par. 11.2 ALARMS THAT STOP THE DISHWASHER.	-	-	-	0
<b>ndL</b>	A read-only parameter and displays the modules installed in the machine. 1 = Left LED bar installed 2 = Right LED bar installed 4 = Water softener / automatic hood-type feeder Esempio: 7= Left led bar: OK Right led bar: OK Power supply unit: OK	-	-	-	-

### 7.4.3 **HCP** Communication and HACCP parameters

Sym.	Parameter Description	Unit	Min	Max	Factory Default
<b>SEr</b>	Serial Device 0 = 8N1 1 = PC connection (DAAS 8E1) 7 = HACCP network (ECAP 8E1+LK485) (LK485 board is necessary) 3 = Connection PC (DAAS 8E1) on the RS485 communication port 7 = Network HACCP available only for board with RS485 communication port	-	0	63	1



<b>Adr</b>	Address. This parameter specifies the address of the appliance into the 'HACCP_network'. Works only if 'HACCP network' is selected (see above parameter).	-	0	255	1
------------	-----------------------------------------------------------------------------------------------------------------------------------------------------------------	---	---	-----	---

#### 7.4.4 **CFG** Configuration parameters

Sym.	Parameter Description	Unit	Min	Max	Factory Default
<b>tYP</b>	Dishwasher Model: 0 = HOOD TYPE	-	0	3	0
<b>boi</b>	Boiler type: 0 = ATMOSPHERIC BOILER 1 = PRESSURE BOILER (next versions) 2 = EXTERNAL BOILER (next versions)	-	0	2	0
<b>dFl</b>	Default model (see Default tables): 1 = HOOD TYPE	-	0	3	-
<b>trc</b>	Solid State Relay (TRIAC). 0 = not enabled; 1 = <b>SOFT START</b> enabled; 3 = <b>SLOW SOFT START</b> enabled.	-	0	3	0
<b>bt</b>	Boiler/Tank heating swap: 0 = boiler heaters and tank heater can work simultaneously; 1 = swap enabled: tank heating starts only boiler temperature is reached; (Note: disabling this function changes the global electrical power of appliance; before enabling this function check available power, supply cable section, fuses in according to User Manual).	-	0	1	1
<b>btF</b>	Tank Filling Mode Enable filling tank by means of rinsing cycles. Ex: <b>btF</b> = 75 means that boiler water is heated at 75°C, then follows a rinse phase and so on until tank is full. If <b>btF</b> = 0 the tank is filled by solenoid valve in the traditional way (On machines with incorporated continuous water softener, even if <b>btF</b> is set to 0, filling occurs through subsequent rinses).	[°C]	0	85	75
<b>UI</b>	USER INTERFACE MODEL 9 = hood type	-	0	27	9
<b>HiP</b>	Lock button for HIGH PRODUCTIVITY <b>no</b> (the button is not active, the Thermal Label is always active) <b>SEL</b> (the button is active) <b>LOC</b> (the button is not active, the High Productivity is always active)	-	<b>no</b>	<b>LOC</b>	<b>SEL</b>



### 7.4.5 *dLP* Delime cycle parameters (Delime)

Sym.	Parameter Description	Unit	Min	Max	Factory Default
<i>dLE</i>	Delime function enabled	-	no	YES	YES
<i>dAO</i>	Delime Auto OFF 1 = YES = at the end of the Delime cycle, the dishwasher switches off automatically 0 = no = at the end of the Delime cycle, the dishwasher remains on.	-	no	YES	YES
<i>dLA</i>	Select the desired mode Delime: 0 = <i>Gar</i> = with vinegar 1 = <i>Acid</i> = with acid	-	-	-	<i>Gar</i>

#### How to do a Delime cycle (ordinary maintenance)

Proceed as follows:

**Delime cycle with vinegar:** insert the Delime tube present in the machine, identified by an appropriate label, in a container with at least 2l of wine vinegar 6% (2l is the minimum amount of vinegar needed for a correct Delime cycle).

It is advisable to run this cycle according to that given in the table:

Water hardness			The Delime cycle should be run approximately every (*):	Using cycle 2 for 30 cycles/day, the Delime cycle should be run approximately every (*):
°f	°d	°e	Cycles	Days
5	2,8	3,5	1500	50
10	5,6	7,0	750	25
15	8,4	10,5	510	17
20	11,2	14	380	13
25	14	17,5	300	10
30	16,8	21,1	250	8

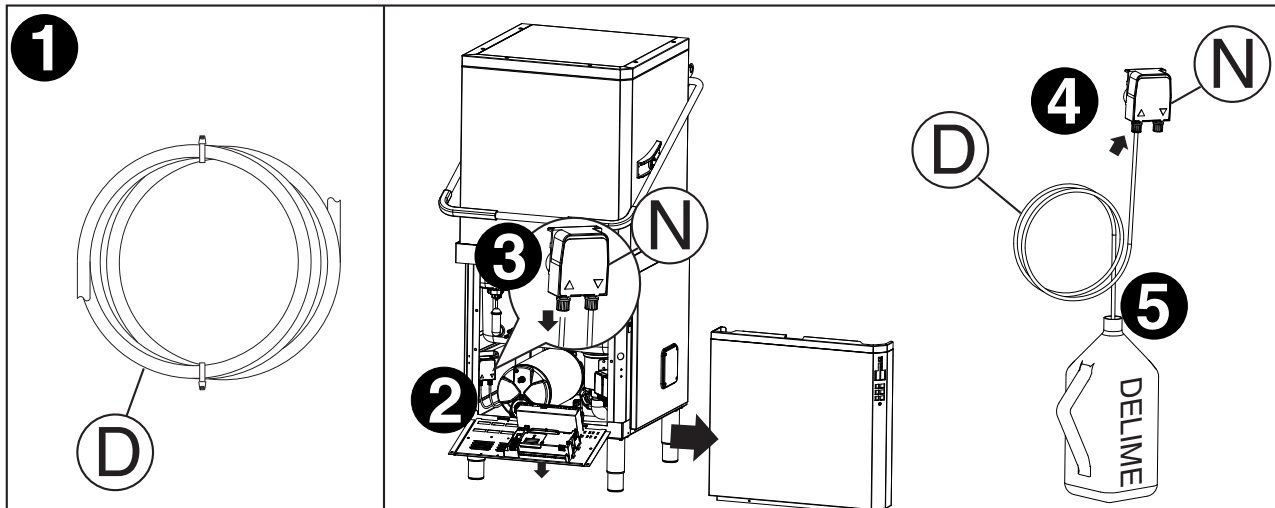
(\*) Considering a rinse time according to the factory settings.

#### WARNING:

**Only use wine vinegar and not other descaling substances. Descaling with the use of chemical substances other than vinegar must only be done by a specialized technician.**

#### Delime cycle with acid (can only be activated by a specialised technician)

- In order to avoid accidental contact with the acid by the end user, get a tube "D" (spare part code: 0L1163) to perform the cycle delime.



- Access to the pump delime, in the machine, removing the front panel and lowering the control panel.



3. Disconnect the inlet pipe of pump "N".
4. Connect the pipe "D" at the inlet connection of pump "N".
5. Introduce the end part of delime pipe "D" in a container with acid (to ensure an adequate descaling, it is recommended to use a solution of phosphoric acid between 30% to 50%).

**WARNING:**

---

**Use appropriate safety measures during descaling operations with acid. Refer to safety data sheets and to labels of the used product.**

---

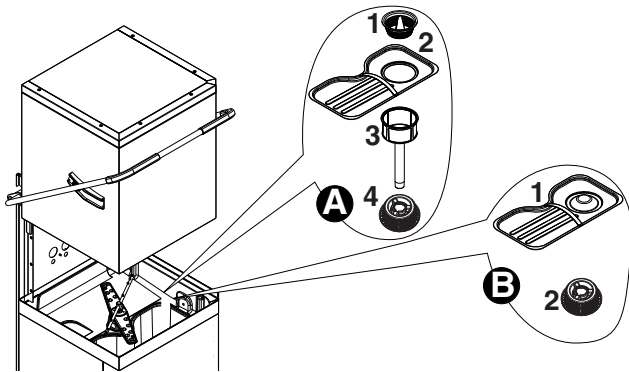
**WARNING:**

---

**Make sure that the drain is properly installed according to the hydraulic circuit diagrams and installation diagrams as described in the instruction manual.**

---

- Lift the hood and take out the rack and eventual dishes.
- In versions with supplementary filtering system (FS), remove the basket filter "1", the flat filter "2", the tank filter "3" and the pump suction filter "4" ("A" - see below).
- In versions without supplementary filtering system (FS), remove the flat filter "1" and the pump suction filter "2" ("B" - see below).



Close the hood.

Press the button "N" (see Par. 1.1 DESCRIPTION OF CONTROL PANEL), for at least 5 seconds,



to run a machine water circuit delime cycle.

**WARNING:**

---

**The delime cycle lasts about 1h 30 sec; during this phase the hood must not be opened and no other command can be activated until completion of the cycle in progress. If the machine is turned off during the delime cycle, at the next restart the cycle will resume exactly from where it was interrupted, until its completion.**

**To cancel the cycle DELIME, if accidentally activated, press at the same time the On/Off and Delime buttons for 5 seconds. The cycle is canceled.**

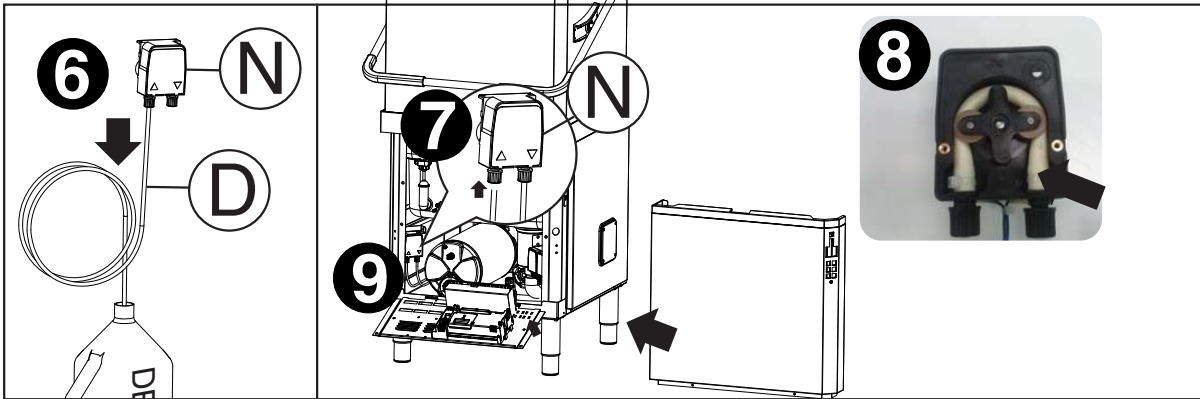
---

At the end of Delime cycle, the dishwasher sounds a series of beeps and "END" will flash on the display. Refit the previously removed overflow.

**If you have performed a delime cycle with acid, do the following operations:**



6. Remove the pipe "D".



7. Reconnect the inlet hose to the pump "N".

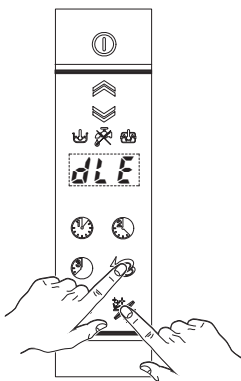
8. Replace the delime pump pipe as described in par. 6.1.1 Peristaltic tube fitting and replacement instructions.

9. Reclose the previously removed panels.

**WARNING:**

**Make sure that at the end of descaling, the container with acid is removed.**

**7.4.6 DELIME DISPENSER ACTIVATION**



1. Switch on the dishwasher.
2. Press at the same time the Delime cycle and the High Productivity button ("L" - "N" Par. 1.1 DESCRIPTION OF CONTROL PANEL). You can hear 2 acoustic signal and the Delime dispenser starts working for 20 seconds.
3. If you press again the buttons "L" e "N" the Delime dispenser stop working.

**7.4.7 ESD Energy saving device parameters (ESD)**

Sym.	Parameter Description	Unit	Min	Max	Factory Default
Fdy	Energy recovery fan operation time at the end of the wash cycle.	s	0	20	10



### 7.4.8 **ASO** Water softener parameters

Sym.	Parameter Description	Unit	Min	Max	Factory Default
<b>Hd</b>	Water hardness [1 °f = 1 French degree = 10 mg/l or ppm of CaCo3] [1 °d =1 German degree = 1.78 French degrees (1 °d = 1.78 °f)] If zero it means that the water softener is not installed.	°f	0	60	0
<b>nrE</b>	Regeneration cycles done (counter not resettable).	-	-	-	-
<b>[nS</b>	Wash cycles done with depleted resins (counter not resettable).	-	-	-	-
<b>FrG</b>	Forced start of a resin regeneration cycle.	-	no	YES	no

### 7.4.9 **SY5** System parameters

Sym.	Parameter Description	Unit	Min	Max	Factory Default
<b>tL</b>	Show the tank level. (Check if the tank level sensor work properly)	mmH <sub>2</sub> O	-	-	-
<b>[y5</b>	Set cycle. (Show the set cycle.)	-	-	-	-



## 8 DEFAULT VALUES

### Default 1 - HOOD TYPE

USr		FAC													
dis ↔	Ent	ba1 ↔	tub ↔	LY1 ↔	LY2 ↔	LY3 ↔	drn ↔	dPA ↔	ran ↔	HCP ↔	CFG ↔	dLP ↔	ESd ↔	ASa	SYS
dun:0-1	LYC	btE: 78	ttE: 63	Ln1: 0	Ln2: 1	Ln3: 2	ldr: 40	lPA: 0	CA1: 1	SEr: 1	tYP: 0	dLE: YES	FdY: 10	Hd: 0	tL
dIn: 200	cYc	btH: 2	ttH: 5	Sh1: 33	Sh2: 12	Sh3: 18	Fdr: 80	Pdr: 0	C 9	Rdr: 1	ba1: 0	dLA: GAR		nrE	LY5
rIn: 0.12	L	bH1: 98	tH1: 85	PA1: 4	PA2: 4	PA3: 4	drk: 0	rPA: 0	NdL		dFL: -			Ln5	
dEt: 200	Lrk	bLo: 1	tLo: 1	r1: 85	r2: 85	r3: 85		C F: C			brc: 1			FrG: no	
rA1: 0.12	rSt	bFL: 5	tFL: 20	dr1: 12	dr2: 12	dr3: 12		rik: no			b_k: 1				
	drn	bAD: 4	L1: 100	FP1: 0	FP2: 0	FP3: 0					btF: 75				
	dLE	bP: YES	L1H: 65	tL1: 0	tL2: 1	tL3: 2					U1: 9				
		bSt: 2	L2: 180	tS1: 45	tS2: 12	tS3: 18									
		btD: 0	L2H: 60			bt3: 0									
		bPo: 50	Ldr: 8												
		bPu: H1	cYd: 0												
		btL: 86	LPd: 20												
			PPd: 6												
			ttL: 75												
			ttH: 2												



## 9 MAIN BOARD CONFIGURATION

When receiving an electronic board (spare part) may be necessary to configure it in according to the machine where has to be replaced

1. With the machine **CODE** enter into the following table and read the corresponding **Prog.** number
2. Follow the instructions reported into the corresponding **Prog.XXX** sheet (next pages).
3. With the machine **CODE** find the **Layout** number in Par. 9.3.1 Connectors layout.

### 9.1 CODE -> Prog. TABLE

MODELLO	CODICE	Prog.	Layout
EHT8TIEL	504250	202	1
EHT8TIL	504251	203	1
EHT8TIELG4	504252	210	1
EHT8TIELG8	504253	210	1
EHT8IELG	504254	202	1
EHT8IEWSG	504255	205	1
EHT8ILG	504256	207	1
EHT8IWSG	504257	204	1
EHT8IG	504258	201	1
EHT8I	504259	201	1
EHT8IROW	504260	212	1
EHT8IROW6	504261	212	1
EHT8ILG4	504262	209	1
EHT8ILG8	504263	209	1
EHT8IUSPH5	504264	213	1
EHT8IUSPH6	504265	213	1
ET12SD	504266	206	1
EHT8IS	504267	201	1
ZHT8TIEL	504270	202	1
ZHT8TIL	504271	203	1
ZHT8IELG	504272	202	1
ZHT8ILG	504273	207	1
ZHT8IWSG	504274	204	1
ZHT8IG	504275	201	1
ZHT8I	504276	201	1
ZHT8IROW	504277	212	1
ZHT8IROW6	504278	212	1
EHT8IELG4	504279	210	1
EHT8IELG8	504280	210	1
NHT8ILG	504283	207	1
NHT8IWSG	504284	204	1
NHT8IG	504285	201	1
NHT8IELG	504286	202	1
NHT8IEWSG	504287	205	1
EHT8IELG6	504288	202	1
NHT8ROW	505066	212	1
NHT8O	505067	201	1
NHT8ROW6	505068	212	1
NHT8O6	505069	201	1
NHT8G	505070	201	1
NHT8	505071	201	1

MODELLO	CODICE	Prog.	Layout
NHT8WSG	505072	204	1
EHT8ROW	505073	212	1
EHT8O	505074	201	1
EHT8ROW6	505075	212	1
EHT8O6	505076	201	1
EHT8J	505077	214	1
EHT8J6	505078	214	1
EHT8M	505079	211	1
EHT8M6	505080	211	1
KHT8	505081	201	1
NHT8GUK	505083	201	1
NHT8DD	505084	201	1
NHT8WSGUK	505085	204	1
NHT8LGUK	505086	207	1
NHT8GRUK	506069	201	1
NHT8LGRUK	506070	207	1
AHT8IWSG	698066	204	1
AHT8IG	698067	201	1



## 9.2 PROGRAMMING SHEETS

MANUAL HT		PROG 201
1. Switch OFF and then switch ON the machine.		
2.	<b>[FG]</b>	Enter into <b>[FE]</b> parameter family, choose <b>[FG]</b> parameter family and set the following parameters:
	<b>tYP</b>	<b>0</b> Hood Type.
	<b>bo i</b>	<b>0</b> Atmospheric boiler.
	<b>dFl</b>	<b>0</b> Default values for Hood type models.
	<b>trc</b>	<b>1</b> SOFT START enabled.
	<b>b_t</b>	<b>1</b> Tank heater works only if boiler temperature reached.
	<b>b_tF</b>	<b>75</b> Enable filling tank by means of rinsing cycles.
	<b>U i</b>	<b>9</b> Select user interface hood type model.
3. Switch OFF and then switch ON the machine.		

MANUAL HT + Delime + Energy Saving Device AUTOMATIC HT + Delime + Energy Saving Device		PROG 202
1. Switch OFF and then switch ON the machine.		
2.	<b>[FG]</b>	Enter into <b>[FE]</b> parameter family, choose <b>[FG]</b> parameter family and set the following parameters:
	<b>tYP</b>	<b>0</b> Hood Type.
	<b>bo i</b>	<b>0</b> Atmospheric boiler.
	<b>dFl</b>	<b>0</b> Default values for Hood type models.
	<b>trc</b>	<b>1</b> SOFT START enabled.
	<b>b_t</b>	<b>1</b> Tank heater works only if boiler temperature reached.
	<b>b_tF</b>	<b>75</b> Enable filling tank by means of rinsing cycles.
	<b>U i</b>	<b>9</b> Select user interface hood type model.
3. Switch OFF and then switch ON the machine.		
4. Parameters setting for ESD.		
	<b>[Y1]</b>	Enter into <b>[FE]</b> parameter family, choose <b>[Y1]</b> parameter family and set the following parameter:
	<b>FP1</b>	<b>12</b> Final pause.
	<b>[Y2]</b>	Choose <b>[Y2]</b> parameter family and set the following parameter:
	<b>FP2</b>	<b>12</b> Final pause.
	<b>[Y3]</b>	Choose <b>[Y3]</b> parameter family and set the following parameter:
	<b>FP3</b>	<b>12</b> Final pause.
5. Activation Delime function		
6.	<b>dLP</b>	Choose <b>dLP</b> parameter family and modify the following parameter:
	<b>dLE</b>	<b>YES</b> Delime function activated.
7. Switch OFF and then switch ON the machine.		



<b>AUTOMATIC HT + Delime</b>		<b>PROG 203</b>
1. Switch OFF and then switch ON the machine.		
2.	<b>CFG</b>	Enter into <b>FRL</b> parameter family, choose <b>CFG</b> parameter family and set the following parameters:
	<b>tYP</b>	<b>0</b> Hood Type.
	<b>boi</b>	<b>0</b> Atmospheric boiler.
	<b>dFL</b>	<b>0</b> Default values for Hood type models.
	<b>trc</b>	<b>1</b> SOFT START enabled.
	<b>b_t</b>	<b>1</b> Tank heater works only if boiler temperature reached.
	<b>btF</b>	<b>75</b> Enable filling tank by means of rinsing cycles.
	<b>UI</b>	<b>9</b> Select user interface hood type model.
3. Switch OFF and then switch ON the machine.		
4. Parameters setting.		
	<b>Y1</b>	Enter into <b>FRL</b> parameter family, choose <b>Y1</b> parameter family and set the following parameter:
	<b>FP1</b>	<b>2</b> Final pause.
	<b>Y2</b>	Choose <b>Y2</b> parameter family and set the following parameter:
	<b>FP2</b>	<b>2</b> Final pause.
	<b>Y3</b>	Choose <b>Y3</b> parameter family and set the following parameter:
	<b>FP3</b>	<b>2</b> Final pause.
5. Activation Delime function		
6.	<b>dLP</b>	Choose <b>dLP</b> parameter family and modify the following parameter:
	<b>dLE</b>	<b>YES</b> Delime function activated.
7. Switch OFF and then switch ON the machine.		

<b>MANUAL HT + Water Softner</b>		<b>PROG 204</b>
1. Switch OFF and then switch ON the machine.		
2.	<b>CFG</b>	Enter into <b>FRL</b> parameter family, choose <b>CFG</b> parameter family and set the following parameters:
	<b>tYP</b>	<b>0</b> Hood Type.
	<b>boi</b>	<b>0</b> Atmospheric boiler.
	<b>dFL</b>	<b>0</b> Default values for Hood type models.
	<b>trc</b>	<b>1</b> SOFT START enabled.
	<b>b_t</b>	<b>1</b> Tank heater works only if boiler temperature reached.
	<b>btF</b>	<b>75</b> Enable filling tank by means of rinsing cycles.
	<b>UI</b>	<b>9</b> Select user interface hood type model.
3. Switch OFF and then switch ON the machine.		
4. Water Softner activation device:		
	<b>RSa</b>	Enter into <b>FRL</b> parameter family, choose <b>RSa</b> and modify the following parameter:
	<b>Hd</b>	Set the value of the water supply hardness French degrees (°f). [Contact your local water authority, to know the water hardness degree.]
5. Switch OFF and then switch ON the machine.		



MANUAL HT + Energy Saving Device + Water Softner		PROG 205
1. Switch OFF and then switch ON the machine.		
2.	<b>CFG</b>	Enter into <b>FRL</b> parameter family, choose <b>CFG</b> parameter family and set the following parameters:
	<b>tYP</b>	<b>0</b> Hood Type.
	<b>boi</b>	<b>0</b> Atmospheric boiler.
	<b>dFl</b>	<b>0</b> Default values for Hood type models.
	<b>trc</b>	<b>1</b> SOFT START enabled.
	<b>b_t</b>	<b>1</b> Tank heater works only if boiler temperature reached.
	<b>btF</b>	<b>75</b> Enable filling tank by means of rinsing cycles.
	<b>UI</b>	<b>9</b> Select user interface hood type model.
3. Switch OFF and then switch ON the machine.		
4. Parameters setting for ESD.		
	<b>Y1</b>	Enter into <b>FRL</b> parameter family, choose <b>Y1</b> parameter family and set the following parameter:
	<b>FP1</b>	<b>12</b> Final pause.
	<b>Y2</b>	Choose <b>Y2</b> parameter family and set the following parameter:
	<b>FP2</b>	<b>12</b> Final pause.
	<b>Y3</b>	Choose <b>Y3</b> parameter family and set the following parameter:
	<b>FP3</b>	<b>12</b> Final pause.
5. Water Softner activation device:		
	<b>RSa</b>	Enter into <b>FRL</b> parameter family, choose <b>RSa</b> and modify the following parameter:
	<b>Hd</b>	Set the value of the water supply hardness French degrees (°f). [Contact your local water authority, to know the water hardness degree.]
6. Switch OFF and then switch ON the machine.		

MANUAL HT + Delime - ECOLAB		PROG 206
1. Switch OFF and then switch ON the machine.		
2.	<b>CFG</b>	Enter into <b>FRL</b> parameter family, choose <b>CFG</b> parameter family and set the following parameters:
	<b>tYP</b>	<b>0</b> Hood Type.
	<b>boi</b>	<b>0</b> Atmospheric boiler.
	<b>dFl</b>	<b>0</b> Default values for Hood type models.
	<b>trc</b>	<b>1</b> SOFT START enabled.
	<b>b_t</b>	<b>1</b> Tank heater works only if boiler temperature reached.
	<b>btF</b>	<b>75</b> Enable filling tank by means of rinsing cycles.
	<b>UI</b>	<b>9</b> Select user interface hood type model.
	<b>H,P</b>	<b>no</b> «High Productivity» function disabled.
3. Switch OFF and then switch ON the machine.		
4. Dispenser parameters configuration.		
5.	<b>d15</b>	Enter in <b>USR</b> parameter family, choose <b>d15</b> and modify the following parameters.
	<b>dun</b>	<b>SEC</b> Measurement units in seconds.
	<b>dIn</b>	<b>55</b> Initial Detergent Dosage in seconds.
	<b>rIn</b>	<b>5</b> Initial Rinse Aid Dosage in seconds.
	<b>dEt</b>	<b>181</b> The detergent dispenser works when WASHING PUMP is being activated. (See §5).
	<b>rA1</b>	<b>61</b> The Rinse Aid dispenser works when LOADING EV is being activated (See §5).
6. Activation Delime function		
7.	<b>dLP</b>	Choose <b>dLP</b> parameter family and modify the following parameter:
	<b>dLE</b>	<b>YES</b> Delime function activated.
8. Switch OFF and then switch ON the machine.		



MANUAL HT + Delime		PROG 207
1. Switch OFF and then switch ON the machine.		
2.	<b>CFG</b>	Enter into <b>FRL</b> parameter family, choose <b>CFG</b> parameter family and set the following parameters:
	<b>tYP</b>	<b>0</b> Hood Type.
	<b>boi</b>	<b>0</b> Atmospheric boiler.
	<b>dFL</b>	<b>0</b> Default values for Hood type models.
	<b>trc</b>	<b>1</b> SOFT START enabled.
	<b>b.t</b>	<b>1</b> Tank heater works only if boiler temperature reached.
	<b>btF</b>	<b>75</b> Enable filling tank by means of rinsing cycles.
	<b>UI</b>	<b>9</b> Select user interface hood type model.
3. Switch OFF and then switch ON the machine.		
4. Activation Delime function		
5.	<b>dLP</b>	Choose <b>dLP</b> parameter family and modify the following parameter:
	<b>dLE</b>	<b>YES</b> Delime function activated.
6. Switch OFF and then switch ON the machine.		

MANUAL HT + Energy Saving Device AUTOMATIC HT + Energy Saving Device		PROG 208
1. Switch OFF and then switch ON the machine.		
2.	<b>CFG</b>	Enter into <b>FRL</b> parameter family, choose <b>CFG</b> parameter family and set the following parameters:
	<b>tYP</b>	<b>0</b> Hood Type.
	<b>boi</b>	<b>0</b> Atmospheric boiler.
	<b>dFL</b>	<b>0</b> Default values for Hood type models.
	<b>trc</b>	<b>1</b> SOFT START enabled.
	<b>b.t</b>	<b>1</b> Tank heater works only if boiler temperature reached.
	<b>btF</b>	<b>75</b> Enable filling tank by means of rinsing cycles.
	<b>UI</b>	<b>9</b> Select user interface hood type model.
3. Switch OFF and then switch ON the machine.		
4. Parameters setting for ESD.		
	<b>Y1</b>	Enter into <b>FRL</b> parameter family, choose <b>Y1</b> parameter family and set the following parameter:
	<b>FP1</b>	<b>12</b> Final pause.
	<b>Y2</b>	Choose <b>Y2</b> parameter family and set the following parameter:
	<b>FP2</b>	<b>12</b> Final pause.
	<b>Y3</b>	Choose <b>Y3</b> parameter family and set the following parameter:
	<b>FP3</b>	<b>12</b> Final pause.
5. Switch OFF and then switch ON the machine.		

MANUAL HT + Delime - USA		PROG 209
1. Switch OFF and then switch ON the machine.		
2.	<b>CFG</b>	Enter into <b>FRL</b> parameter family, choose <b>CFG</b> parameter family and set the following parameters:
	<b>tYP</b>	<b>0</b> Hood Type.
	<b>boi</b>	<b>0</b> Atmospheric boiler.
	<b>dFL</b>	<b>0</b> Default values for Hood type models.
	<b>trc</b>	<b>1</b> SOFT START enabled.
	<b>b.t</b>	<b>1</b> Tank heater works only if boiler temperature reached.



	<b>btF</b>	<b>75</b>	Enable filling tank by means of rinsing cycles.
	<b>U1</b>	<b>9</b>	Select user interface hood type model.
3.	Switch OFF and then switch ON the machine.		
4.	Set the measurement units.		
5.	<b>dPA</b>	Enter in <b>FAL</b> parameter family, choose <b>dPA</b> and modify the following parameters.	
	<b>CF</b>	<b>F</b>	Setting temperature in Fahrenheit.
6.	Activation Delime function		
7.	<b>dLP</b>	Choose <b>dLP</b> parameter family and modify the following parameter:	
	<b>dLE</b>	<b>YES</b>	Delime function activated.
8.	Switch OFF and then switch ON the machine.		

<b>MANUAL HT+ Delime + Energy Saving Device - USA</b>		<b>PROG 210</b>	
<b>AUTOMATIC HT+ Delime + Energy Saving Device - USA</b>			
1.	Switch OFF and then switch ON the machine.		
2.	<b>CFG</b>	Enter into <b>FAL</b> parameter family, choose <b>CFG</b> parameter family and set the following parameters:	
	<b>tYP</b>	<b>0</b>	Hood Type.
	<b>boi</b>	<b>0</b>	Atmospheric boiler.
	<b>dFL</b>	<b>0</b>	Default values for Hood type models.
	<b>trc</b>	<b>1</b>	SOFT START enabled.
	<b>b_t</b>	<b>1</b>	Tank heater works only if boiler temperature reached.
	<b>btF</b>	<b>75</b>	Enable filling tank by means of rinsing cycles.
	<b>U1</b>	<b>9</b>	Select user interface hood type model.
3.	Switch OFF and then switch ON the machine.		
4.	Parameters setting for ESD.		
	<b>CY1</b>	Enter into <b>FAL</b> parameter family, choose <b>CY1</b> parameter family and set the following parameter:	
	<b>FP1</b>	<b>12</b>	Final pause.
	<b>CY2</b>	Choose <b>CY2</b> parameter family and set the following parameter:	
	<b>FP2</b>	<b>12</b>	Final pause.
	<b>CY3</b>	Choose <b>CY3</b> parameter family and set the following parameter:	
	<b>FP3</b>	<b>12</b>	Final pause.
5.	Set the measurement units.		
6.	<b>dPA</b>	Enter in <b>FAL</b> parameter family, choose <b>dPA</b> and modify the following parameters.	
	<b>CF</b>	<b>F</b>	Setting temperature in Fahrenheit.
7.	Activation Delime function		
8.	<b>dLP</b>	Choose <b>dLP</b> parameter family and modify the following parameter:	
	<b>dLE</b>	<b>YES</b>	Delime function activated.
9.	Switch OFF and then switch ON the machine.		

<b>MANUAL HT - MARINE</b>		<b>PROG 211</b>	
1.	Switch OFF and then switch ON the machine.		
2.	<b>CFG</b>	Enter into <b>FAL</b> parameter family, choose <b>CFG</b> parameter family and set the following parameters:	
	<b>tYP</b>	<b>0</b>	Hood Type.
	<b>boi</b>	<b>0</b>	Atmospheric boiler.
	<b>dFL</b>	<b>0</b>	Default values for Hood type models.
	<b>trc</b>	<b>0</b>	SOFT START enabled.
	<b>b_t</b>	<b>1</b>	Tank heater works only if boiler temperature reached.
	<b>btF</b>	<b>75</b>	Enable filling tank by means of rinsing cycles.
	<b>U1</b>	<b>9</b>	Select user interface hood type model.
3.	Switch OFF and then switch ON the machine.		



HT MANUALI - ASIA		PROG 212	
1. Switch OFF and then switch ON the machine.			
2.	<b>CFG</b>	Enter into <b>FRL</b> parameter family, choose <b>CFG</b> parameter family and set the following parameters:	
	<b>tYP</b>	<b>0</b>	Hood Type.
	<b>boi</b>	<b>0</b>	Atmospheric boiler.
	<b>dFl</b>	<b>0</b>	Default values for Hood type models.
	<b>trc</b>	<b>1</b>	SOFT START enabled.
	<b>b_t</b>	<b>1</b>	Tank heater works only if boiler temperature reached.
	<b>btF</b>	<b>75</b>	Enable filling tank by means of rinsing cycles.
	<b>UI</b>	<b>9</b>	Select user interface hood type model.
	<b>HiP</b>	<b>no</b>	«High Productivity» function disabled.
3. Switch OFF and then switch ON the machine.			

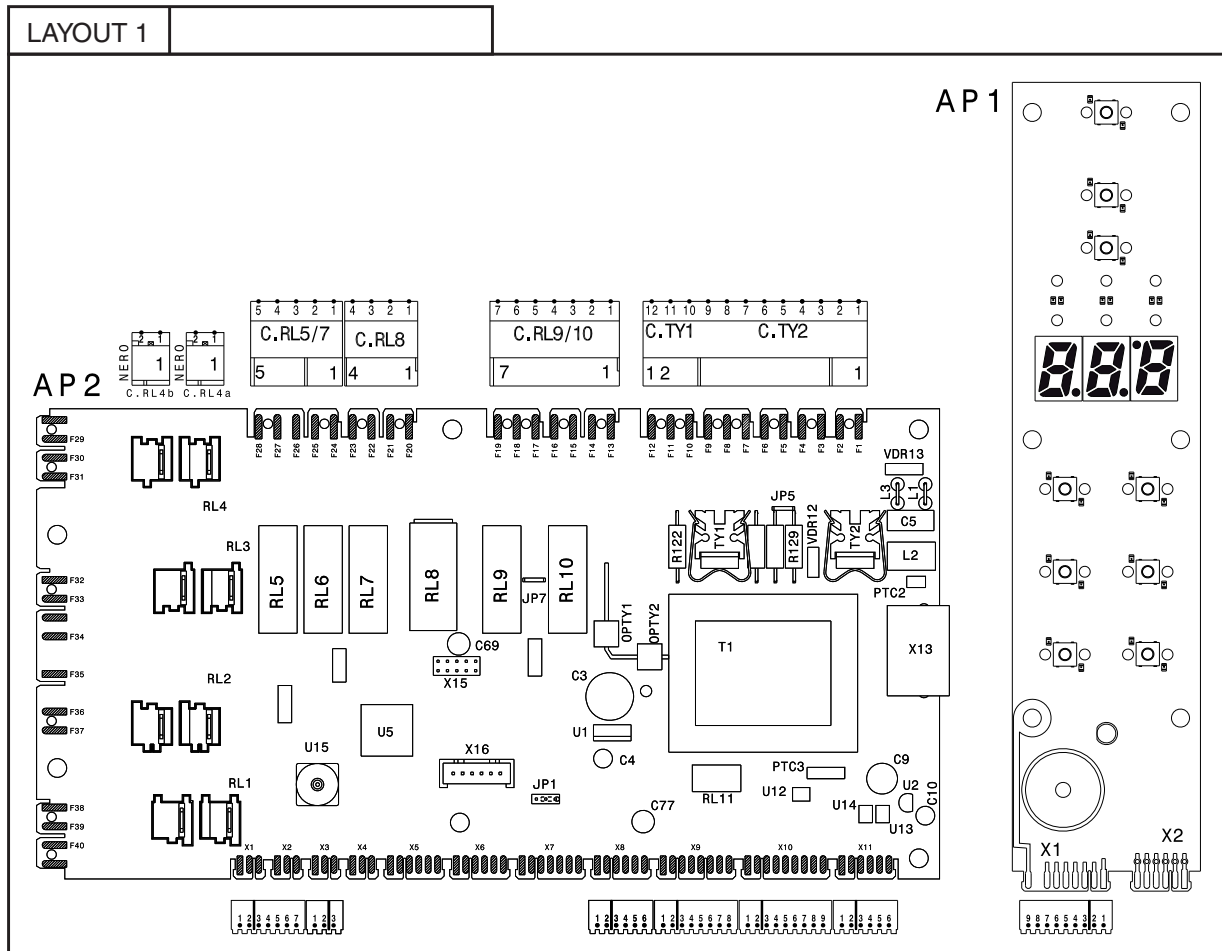
HT MANUALI - USPH		PROG 213	
1. Switch OFF and then switch ON the machine.			
2.	<b>CFG</b>	Enter into <b>FRL</b> parameter family, choose <b>CFG</b> parameter family and set the following parameters:	
	<b>tYP</b>	<b>0</b>	Hood Type.
	<b>boi</b>	<b>0</b>	Atmospheric boiler.
	<b>dFl</b>	<b>0</b>	Default values for Hood type models.
	<b>trc</b>	<b>0</b>	SOFT START enabled.
	<b>b_t</b>	<b>1</b>	Tank heater works only if boiler temperature reached.
	<b>btF</b>	<b>75</b>	Enable filling tank by means of rinsing cycles.
	<b>UI</b>	<b>9</b>	Select user interface hood type model.
3. Switch OFF and then switch ON the machine.			
4. Set the measurement units.			
5.	<b>dPR</b>	Enter in <b>FRL</b> parameter family, choose <b>dPR</b> and modify the following parameters.	
	<b>CF</b>	<b>F</b>	Setting temperature in Fahrenheit.
6. Switch OFF and then switch ON the machine.			

HT MANUALI - Japan		PROG 214	
1. Switch OFF and then switch ON the machine.			
2.	<b>CFG</b>	Enter into <b>FRL</b> parameter family, choose <b>CFG</b> parameter family and set the following parameters:	
	<b>tYP</b>	<b>0</b>	Hood Type.
	<b>boi</b>	<b>0</b>	Atmospheric boiler.
	<b>dFl</b>	<b>0</b>	Default values for Hood type models.
	<b>trc</b>	<b>0</b>	SOFT START enabled.
	<b>b_t</b>	<b>0</b>	Tank heater and boiler ones works together.
	<b>btF</b>	<b>75</b>	Enable filling tank by means of rinsing cycles.
	<b>UI</b>	<b>9</b>	Select user interface hood type model.
3. Switch OFF and then switch ON the machine.			



## 9.3 USER INTERFACE AND MAIN BOARD CONNECTORS

### 9.3.1 Connectors layout



#### KEY

- C.TY1/C.TY2 Board power supply input
- Wash pump/rinse pump outputs
- C.RL1a/b Boiler heating element and boiler heating element contactor input/output
- C.RL2a/b Boiler heating element input/output
- C.RL3a/b Boiler heating element input/output
- C.RL4a/b Tank heating element and tank heating element relay input/output
- C.RL5/7 ESD fans and drain pump/solenoid valve outputs
- C.RL8 Door microswitch
- C.RL9/10 Detergent/rinse aid dispenser outputs
- C.X1/X2 Temperature sensor inputs
- C.X3 Pick control input
- C.X8/X9 Pressure sensor inputs
- C.X10 User interface inputs/outputs
- C.X11 Main and user interface communication
- C.API.X1 Hood sensor input and user interface inputs/outputs



## 10 DISHWASHER SETTING IN PREWASH MODE

Use ONLY the washing cycle 3 ("1" - Par. 1.1 DESCRIPTION OF CONTROL PANEL) and set the appliance as you can see in the table below.

1. Switch OFF and then switch ON the machine.			
2. Enter into <b>FR</b> parameter family, choose <b>FE</b> parameter family and set the following parameters:			
<b>ba</b>	<b>bte</b>	<b>44</b>	Boiler heating deactivated
<b>tub</b>	<b>tte</b>	<b>39</b>	Tank heating deactivated
<b>[9]</b>	<b>PA</b>	<b>0</b>	Pause.
	<b>r,3</b>	<b>0</b>	Rinse phase duration
1. Switch OFF and then switch ON the machine.			

## 11 ALARM MESSAGES AND TROUBLESHOOTING

### 11.1 MAIN MALFUNCTIONS NOT DUE TO THE MAIN BOARD

DESCRIPTION	POSSIBLE CAUSE
The display shows <b>CLDSE</b> with door/hood closed	Check door/hood micro/sensor
No cycle starts	Check the user interface buttons (have they remained pressed? etc.)
A cycle fails to start	Is a user interface button extension missing?
Cycle time longer than that foreseen	Do boiler heating elements work properly? Is the feed water at 50°C?

### 11.2 ALARMS THAT STOP THE DISHWASHER

<b>A 1</b>	<p>Want of water</p> <p>Is the water cock open? Does the water load solenoid valve work? Is the water feed flow a min. of 5 l/min? Is the water inlet filter clean? Is the load solenoid valve filter clean? Is the overflow inserted? Do the tank/boiler pressure switches work properly?</p>
<b>[ 9</b>	<p>Automatic hood out of order</p> <p>Alarm codes for automatic hood type dishwasher (see paragraph 11.2.1 Alarm codes for automatic hood type dishwashers).</p>



<b>E 12</b>	<b>Tank level sensor out of order</b>
-------------	---------------------------------------

- Are the connectors correctly connected?
- Are connector contacts cleaned?
- Does the air trap of the tank work correctly?
- Is the level sensor broken (replace it with a new one)?

**11.2.1 Alarm codes for automatic hood type dishwashers**

When the alarm **E 9** appears, to facilitate fault-finding a parameter providing a more detailed indication has been introduced.

The parameter is **E 9** and is found in the **r 0 n** family.

The possible cause of the anomaly can be found (see next table) according to the value of the parameter **E 9**.

E.g.: With an automatic hood type the alarm **E 9** appears.

Access the parameter **E 9** in the **r 0 n** family.

Assuming the value displayed is:

**20** ⇒ During lifting, the current absorbed by the lifting motor has exceeded the threshold. This can happen if a rack or other heavy material was placed on the hood.

<b>Automatic Hood</b>	
<b>E 9</b>	
<b>1</b>	Hood is closed but the upper end limit switch (FC_UP) is active.
<b>2</b>	Hood is opening (starting from completely close position), but the lower end limit switch has not been released.
<b>4</b>	During hood opening the lower end limit switch (FC_DW) has been activated.
<b>5</b>	Hood opening timeout: hood opening duration must be less than 18s (fixed value). Check if the motor works properly.
<b>6</b>	Hood is open but the lower end limit switch is active (FC_DW).
<b>8</b>	Hood is closing (starting from completely open position) but the upper end limit switch has not been released.
<b>10</b>	During hood closing the upper end limit switch (FC_UP) has been activated.
<b>11</b>	Hood closing timeout: hood closing duration must be less than 18s (fixed value). Check if the motor works properly.



<b>14</b>	Combination not allowed: upper end limit switch (FC_UP) and lower end limit switch(FC_DW) are both activated.
<b>20</b>	Overcurrent during hood opening phase.
<b>22</b>	Overcurrent during hood closing phase.
<b>30</b>	On board motor driver overtemperature.

### 11.3 ALARMS THAT DON'T STOP THE DISHWASHER

(SHOWN ON THE USER INTERFACE AT REGULAR INTERVALS)

<b>b 1</b>	<b>Drain not efficient</b>
	Has the overflow been removed? Is the water drain blocked? Is the drain pump blocked? Are the air trap and tank pressure switch clean? Is there a constriction in the drain tube? Is the pump breather pipe returning to the tank clogged or constricted? Does the tank pressure switch work properly? Is there a hole in the drain tube (only for versions with drain pump)?
<b>b 2</b>	<b>Overflow alarm</b>
	Is the water drain blocked? Are the air trap and tank pressure switch clean? Does the tank pressure switch work properly? Is the load solenoid valve blocked? (see electrical wiring diagram - YV1 Filling solenoid valve) Is the load solenoid valve relay stuck? (see electrical wiring diagram - RL5 relay of AP2 board)
<b>E 1</b>	<b>Boiler temperature rise too fast</b>
	Does the boiler level sensor work properly? The boiler could be empty. Are no-original power resistances installed?
<b>E 2</b>	<b>Boiler temperature too high</b>
	Has the boiler temperature been changed ( <b>bE1</b> - increased above 90°C)? Has the software alarm value been modified ( <b>bH 1</b> )? Does the boiler level sensor work properly? Boiler relay/relays sticked (see electrical wiring diagram - RL1/ RL2/ RL3 relays of AP2 board)?
<b>E 3</b>	<b>Tank temperature too high</b>
	Is the feed water above 60°C? Has the software alarm value been modified ( <b>bH 1</b> )? Is the rinse water temperature too high? Is the tank relay stuck (see electrical wiring diagram - RL4 relay of AP2 board)?
<b>E 4</b>	<b>Tank temperature sensor out of order</b>
	Is the temperature sensor broken or disconnected (see electrical wiring diagram - ST1 tank probe)? Is the temperature sensor connector correctly inserted?
<b>E 5</b>	<b>Tank temperature sensor out of order</b>
	Is the temperature sensor short-circuited (see electrical wiring diagram - ST1 Tank probe)?



<b>E 6</b>	<b>Boiler temperature sensor out of order</b>
	Is the temperature sensor broken or disconnected (see electrical wiring diagram - ST2 Boiler probe)? Is the temperature sensor connector correctly inserted?
<b>E 7</b>	<b>Boiler temperature sensor out of order</b>
	Is the temperature sensor short-circuited (see electrical wiring diagram - ST2 boiler probe)?
<b>E 10</b>	<b>Rinse temperature sensor out of order</b> (only on machines with temperature sensor on the rinse circuit)
	Is the temperature sensor broken or disconnected? Is the temperature sensor connector correctly inserted?
<b>E 11</b>	<b>Rinse temperature sensor out of order</b> (only on machines with temperature sensor on the rinse circuit)
	Is the temperature sensor short-circuited?
<b>E 13</b>	<b>Rinse pump out of order</b> (the water level of the boiler does not decrease)
	Does the rinse pump work correctly? Is there any bottleneck in the hose, that connect the air trap and the board sensor?

**WARNING:**

Alarms **E 2**, **E 6** and **E 7** lock the boiler temperature control.

Alarms **E 3**, **E 4** and **E 5** lock the tank temperature control.

In the case of alarms **E 6** and **E 7**, the boiler waiting phase is not executed (the rinse may be performed with cold water) and, during the initial warm-up and subsequent rinses ( **btF** > **0** ), the boiler heating phase is not executed.

In the case of an open probe error ( **E 4**, **E 6** e **E 10** ), the displayed temperature is 10°C

In the case of a shorted probe error ( **E 5**, **E 7** e **E 11** ), the displayed temperature is 99°C.

<b>E 1</b>	<b>Communication error</b>
	Is the connection between main board and control panel correct? Are the connectors correctly connected? Are connector contacts clean?
<b>E 2</b>	<b>Tank temperature low</b>
	Does the tank heating element work properly? Are the connectors correctly connected? Are the dishwasher feed voltage and current correct? Is the relay RL4 (see electrical wiring diagram - RL4 relay of AP2 board) on the board disconnected or faulty?



<b>E 3</b>	<b>Boiler temperature low</b>
	<p>Does/do the boiler heating element/s work properly? Are the connectors correctly connected? Does the possible remote control switch connected to the heating element work correctly? Is there power at the remote control switch input terminals? Do boiler relays (see electrical wiring diagram - RL1/ RL2/ RL3 relays of AP2 board) work properly?</p> <p><u>CAUTION:</u> IF THERE IS A MALFUNCTION ON RELAY RL1 AND THE BOILER HEATING ELEMENTS ARE FED BY MEANS OF A REMOTE CONTROL SWITCH, THE BOARD DOES NOT HAVE TO BE REPLACED; JUST MOVE THE BOILER HEATING ELEMENT CONNECTOR TO ONE OF THE TWO FREE POSITIONS ON THE BOARD.</p> <p><u>CAUTION:</u> WHEN ONE BRANCH OF THE HEATING ELEMENT DOES NOT WORK AND THE OTHER TWO CONTINUE TO FUNCTION, ON REACHING THE SET TEMPERATURE VALUE, ALARM 3 DISAPPEARS AND REAPPEARS IN THE SUBSEQUENT RINSE PHASE. THIS ALSO OCCURS WHEN A PHASE IS MISSING.</p>